

# I/O CONTROLLER

## MMX EC1 GEN.6



## KEY FEATURES

- + 16 Configurable Universal I/O Pins
- + **Digital, Analog**, Resistance And Frequency Inputs
- + **High-Side, Low-Side** and PWM Outputs
- + Integrated **3-Axis Accelerometer**
- + Integrated **I/O Status LEDs**
- + **Expansion Options** Including H-Bridge, IMU, DAC And RS232/485 Interfaces
- + **Scalable Distributed Architecture**



## CONNECTIONS

**Black Connector: Pin Description**

PIN	TYPE	OPTION 1	OPTION 2	OPTION 3	OPTION 4
1	FIXED	BATTERY +	-	-	-
2	FIXED	BATTERY +	-	-	-
3	FIXED	CAN LOW 1	-	-	-
4	CONFIGURABLE	CAN LOW 2 (J1939)	CAN LOW 1	-	-
5	CONFIGURABLE	ANALOG INPUT	DIGITAL INPUT +/-	DIGITAL OUTPUT+	-
6	CONFIGURABLE	ANALOG INPUT	DIGITAL INPUT +/-	DIGITAL OUTPUT+	-
7	CONFIGURABLE	ANALOG INPUT	DIGITAL INPUT +/-	DIGITAL OUTPUT+	RESISTANCE INPUT
8	CONFIGURABLE	ANALOG INPUT	DIGITAL INPUT +/-	DIGITAL OUTPUT+	-
9	CONFIGURABLE	CAN HIGH 2 (J1939)	CAN HIGH 1	-	-
10	FIXED	CAN HIGH 1	-	-	-
11	FIXED	BATTERY -	ANALOG GND	-	-
12	FIXED	BATTERY -	-	-	-

## FLEXIBLE CONTROL PLATFORM FOR ADVANCED VEHICLE SYSTEMS

The **MMX EC1** is a highly flexible distributed I/O controller designed for demanding automotive, special vehicle and industrial applications. It provides an intelligent platform for integrating sensors, switches, actuators and CAN-based devices into a reliable and scalable control system.

As part of the Emitter Electronics MMX product family, the MMX EC1 seamlessly integrates with other MMX devices including HMIs, LCD displays, keypads, pump governors, tank level indicators and additional control modules.

For applications requiring extended I/O capacity, multiple MMX EC1 controllers can be connected over CAN networks using CAN SAE J1939, CANopen or custom communication protocols, enabling scalable and highly configurable system architectures.

**Grey Connector: Pin Description**

PIN	TYPE	OPTION 1	OPTION 2	OPTION 3	OPTION 4	EXTENSION BOARD
1	CONFIGURABLE	DIGITAL INPUT +/-	DIGITAL OUTPUT + PWM	-	-	-
2	CONFIGURABLE	DIGITAL INPUT +/-	DIGITAL OUTPUT + PWM	-	-	-
3	CONFIGURABLE	DIGITAL INPUT +/-	DIGITAL OUTPUT + PWM	-	-	-
4	CONFIGURABLE	DIGITAL INPUT +/-	DIGITAL OUTPUT + PWM	-	-	-
5	CONFIGURABLE	DIGITAL INPUT +/-	DIGITAL OUTPUT + PWM	DIGITAL OUTPUT -	-	EXTENSION A
6	CONFIGURABLE	DIGITAL INPUT +/-	DIGITAL OUTPUT + PWM	DIGITAL OUTPUT -	-	EXTENSION A
7	CONFIGURABLE	DIGITAL INPUT +/-	DIGITAL OUTPUT + PWM	DIGITAL OUTPUT -	-	EXTENSION B
8	CONFIGURABLE	DIGITAL INPUT +/-	DIGITAL OUTPUT + PWM	DIGITAL OUTPUT -	RESISTANCE INPUT	EXTENSION B
9	CONFIGURABLE	DIGITAL INPUT +/-	DIGITAL OUTPUT + PWM*	DIGITAL OUTPUT -	-	EXTENSION C
10	CONFIGURABLE	DIGITAL INPUT +/-	DIGITAL OUTPUT + PWM*	DIGITAL OUTPUT -	-	EXTENSION C
11	CONFIGURABLE	DIGITAL INPUT +/-	DIGITAL OUTPUT + PWM*	DIGITAL OUTPUT -	-	-
12	CONFIGURABLE	DIGITAL INPUT +/-	DIGITAL OUTPUT + PWM*	DIGITAL OUTPUT -	-	-

## BLOCK DIAGRAM

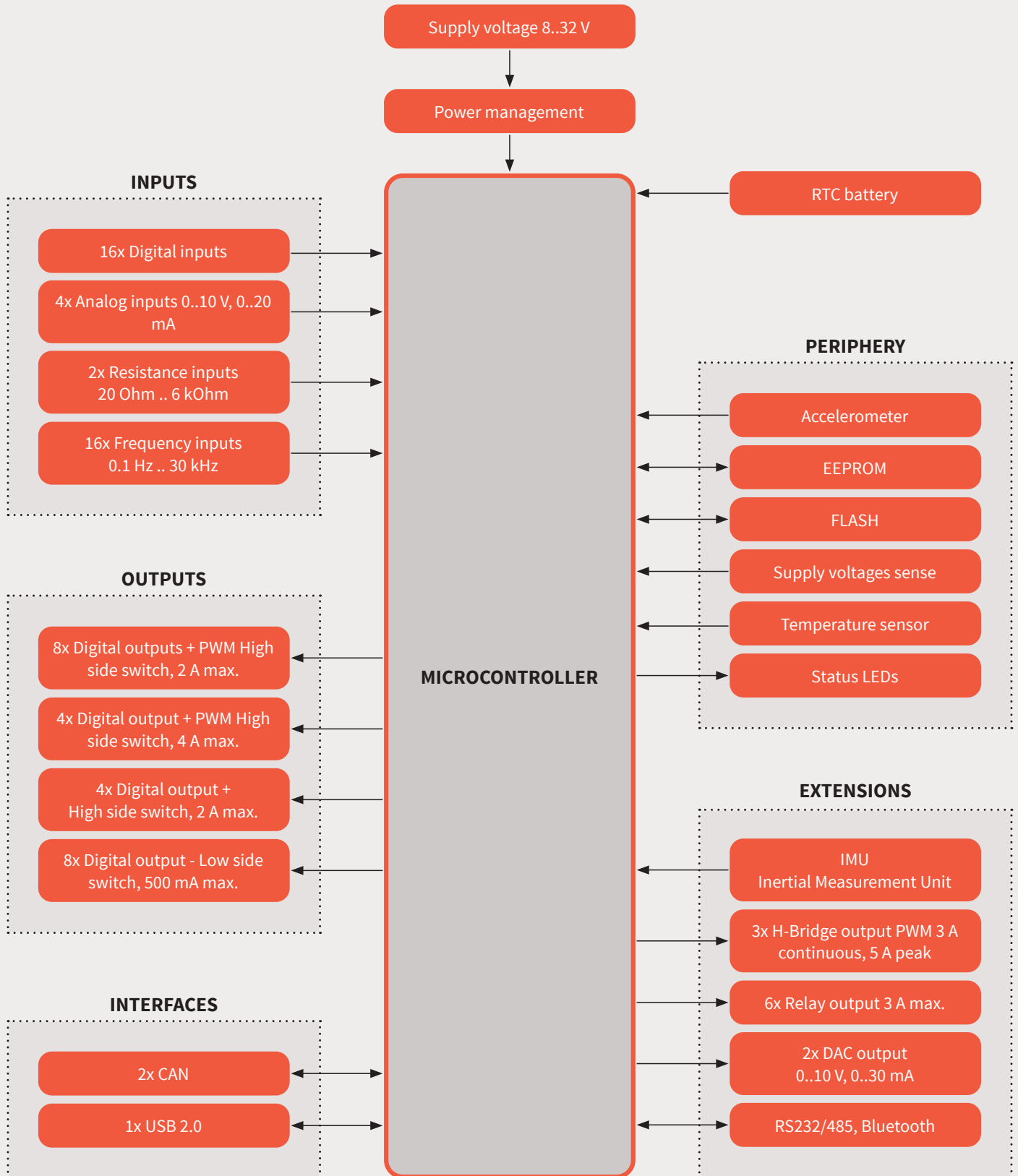

**NOTE:** Block diagram shows all available MMX EC1 G6 controller inputs and outputs - 16 of them can be used simultaneously (MMX EC1 G6 controller has 16 configurable IO pins).

# SPECIFICATIONS

KERNEL		OTHER FEATURES	
<b>Processor</b>	32-bit ARM Cortex-M4, 168 MHz	<b>Accelerometer</b>	integrated 3-axis, MEMS, 12-bit digital accelerometer, +/-2, +/-4, +/-8 g, for inclination/acceleration sensing
<b>Processor flash</b>	1 MByte	<b>IMU</b>	3-axis accelerometer 12-bit, measurement ranges ±2 g, ±4 g, ±8 g, ±16 g, resolution 0.98 mg, 3-axis gyroscope 16-bit, ±125 °/s, ±250 °/s, ±500 °/s, ±1000 °/s, ±2000 °/s, resolution 0.004 °/s, 3-axis magnetometer 16-bit, ±1300 μT (x,y), ±2500 μT (z), resolution 0.3 μT, available via extension board
<b>Processor RAM</b>	192 kByte	<b>Data logger</b>	system information/data logging, optional RTC logging with dedicated 1000 mAh onboard battery
<b>External EEPROM</b>	2 kByte	<b>Monitoring</b>	internal monitoring of power supply voltage, RTC battery voltage, CPU core temperature and board temperature, over/under supply voltage detection, watchdog functionality
<b>External flash</b>	64 MByte	<b>LED diagnostics</b>	dedicated on board status LEDs for I/O pin diagnostics and error indication
I/O PINS		<b>Protections</b>	overvoltage, transients, load dump protection, reverse polarity protection by external fuse
<b>Total</b>	16x universal pins, individually configurable via software, all I/O pins are protected against short circuit to GND and BAT+, each I/O pin is diagnosable via status LEDs	ELECTRICAL & ENVIRONMENTAL REQUIREMENTS	
INPUTS		<b>Supply voltage</b>	8 .. 32 V
<b>Digital input</b>	16x total, configurable integrated pull-up/down resistor and active low/high levels via software, protected	<b>Peak supply voltage</b>	≤ 36 V for ≤ 5 min, ≤ 40 V for ≤ 2 s
<b>Analog input</b>	4x total, 12-bit resolution, configurable voltage/current input via software, 4 .. 20 mA, 0 .. 10 V, out-of-range detection, protected	<b>Idle current</b>	30 mA @ 24 V
<b>Resistance input</b>	2x total, 12-bit resolution, 20 Ohm .. 6 kOhm, Pt1000, Pt100, KTY support, protected	<b>Max total current</b>	15 A
<b>Frequency input</b>	16x total, ≤ 30 kHz, incremental encoder A/B - 8x total, protected	<b>RTC battery life</b>	min. 10 years
OUTPUTS		<b>Operating temperature</b>	-40 .. +85 °C (with full load)
<b>Digital output + PWM</b>	8x total, high side switch, 2 A max., 0 .. 100 %, overload/short circuit protection, overtemperature protection, open load detection	ENCLOSURE	
<b>Digital output + PWM (high current)</b>	4x total, high side switch, 4 A max., 0 .. 100 %, overload/short circuit protection, overtemperature protection, open load detection	<b>Connector</b>	2x 12 pin Deutch DTM connector, waterproof
<b>Digital output +</b>	4x total, high side switch, 2 A max., overload/short circuit protection, overtemperature protection, open load detection	<b>Ingress Protection</b>	EN 60529 IP67
<b>Digital output -</b>	8x total, low side switch, 500 mA max., overload/short circuit protection, overtemperature protection, open load detection	<b>Housing material</b>	Nylon 6/6 black glass fibre reinforced, silicone rubber
<b>DAC output</b>	2x total, 12-bit resolution, available via extension board	<b>Housing dimensions</b>	133 x 119 x 35 mm
Voltage DAC	0 .. 10 V (10mA)	<b>Weight</b>	250 g
Current DAC	0 .. 30 mA	SOFTWARE	
INTERFACES		<b>Programming environment</b>	C/C++, high level API-library included
<b>CAN</b>	2x CAN, ISO 11898 2.0 A/B up to 1 Mbps, protocols SAE J1939, CANopen, free, etc.	STANDARDS	
<b>CAN Link</b>	1x T-connection, configurable termination 120 ohm via DIP switch, node ID definition via software	<b>CE-Mark</b>	2014/30/EU
<b>USB</b>	1x USB 2.0, for firmware update	<b>E-Mark</b>	ECE 10 R-06 noise immunity with 100 V/m
<b>RS232/485, Bluetooth, ...</b>	available via extension boards	<b>EMC</b>	EN 61000-6-2, noise immunity EN 61000-6-4, radiation of interference
		<b>Electrical</b>	ISO 7637-2, pulse immunity, load dump

## DIMENSIONS

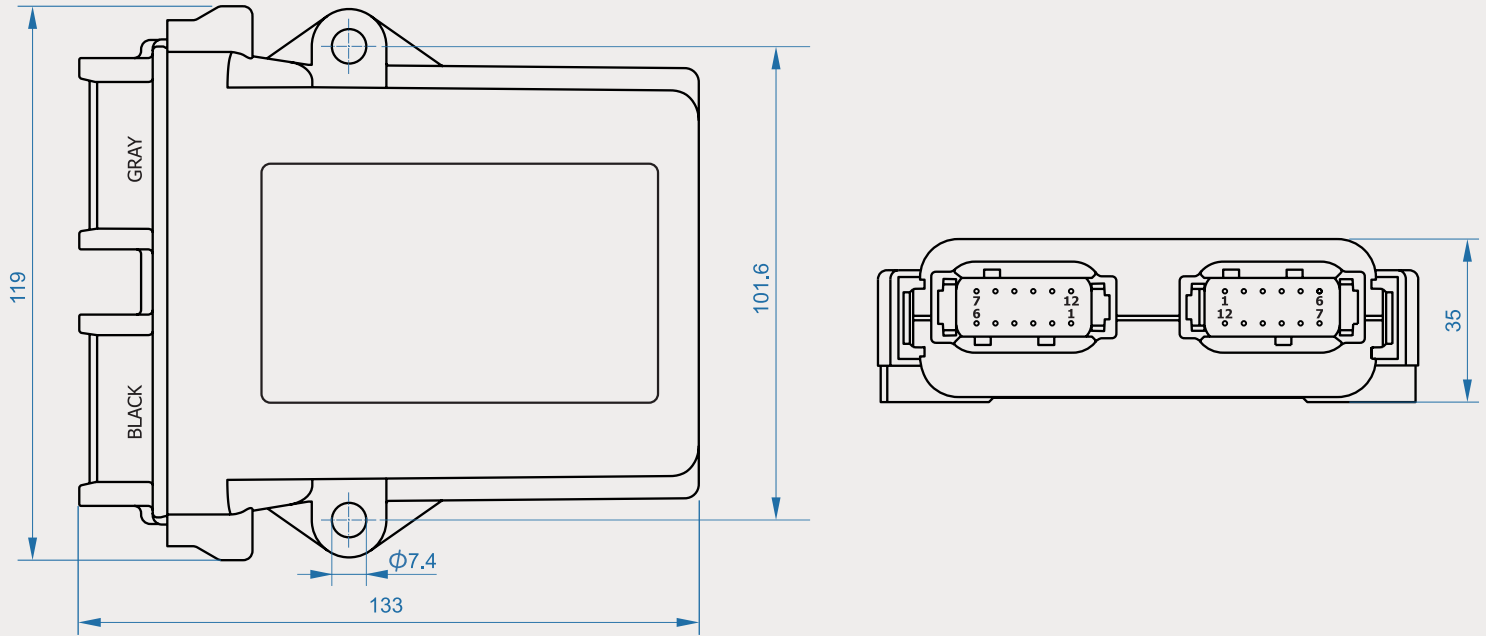

## PRODUCT CODE

Product Code	Total IO	OUT+	OUT+*	OUT-	IN+	IN-	AIN	RIN	F	B	CAN Configuration	EXT1	EXT2	EXT3	Type	Status
MMXEC1-0000-xxxx	16	0	0	0	16	16	4	2	-	-	DIP Switch	-	-	-	TBD	Preview
MMXEC1-0400-xxxx	16	4	0	0	16	12	4	2	-	-	DIP Switch	-	-	-	TBD	Preview
MMXEC1-0600-0012	16	6	2	0	16	10	4	2	-	-	DIP Switch	-	-	-	Standard	Active
MMXEC1-0800-xxxx	16	8	4	0	16	8	4	2	-	-	DIP Switch	-	-	-	TBD	Preview
MMXEC1-1000-xxxx	16	10	2	0	16	6	4	1	-	-	DIP Switch	-	-	-	TBD	Preview
MMXEC1-1200-0013	16	12	4	0	16	4	4	1	-	-	DIP Switch	-	-	-	Standard	Active
MMXEC1-1600-xxxx	16	16	4	0	16	0	0	0	-	-	DIP Switch	-	-	-	TBD	Preview
MMXEC1-1200-0014	16	6	2	6	10	10	4	1	-	-	DIP Switch	-	-	-	Special	Active

\*High current outputs

OUT - Output, IN - Input, AIN - Analog input, RIN - Resistance input, F - Flash, B - Battery, EXT1 - Extension 1, EXT2 - Extension 2, EXT3 - Extension 3

**For other possible IO configurations please contact the supplier.**