



EMITTER
ELECTRONICS
innovative • reliable • flexible



TANK LEVEL GAUGE

INS-20/RIS-20/TLGS-20



Features and Benefits

- 1 **160° Viewing Angle**
- 2 **I/O Driver For Low Water Warning, Autofill-Hysteresis, Mute Input, Large Light Driver, Etc.**
- 3 **CAN Bus Or 1 Wire Datalink**
- 4 **Super Bright LEDs**
- 5 **Dimmable-Light Sensor, Backlit**
- 6 **Multiple Sensor input**

INS-20 types of Tank Level Gauges are designed to display liquid's volume at an accuracy of 1/20 (5%) of the tank level using ultra-bright LEDs. The transducer measures the column of the liquid in the tank above the sensor process input and provides a signal that is proportional to the tank height. The unit standardly uses a pressure transducer with output 0.5-4.5 V by which we can detect also broken sensor cable. The sensor input is widely configurable and it can also be used for 0-10 V transducers or 4-20 mA transmitters.

V1.0-190915

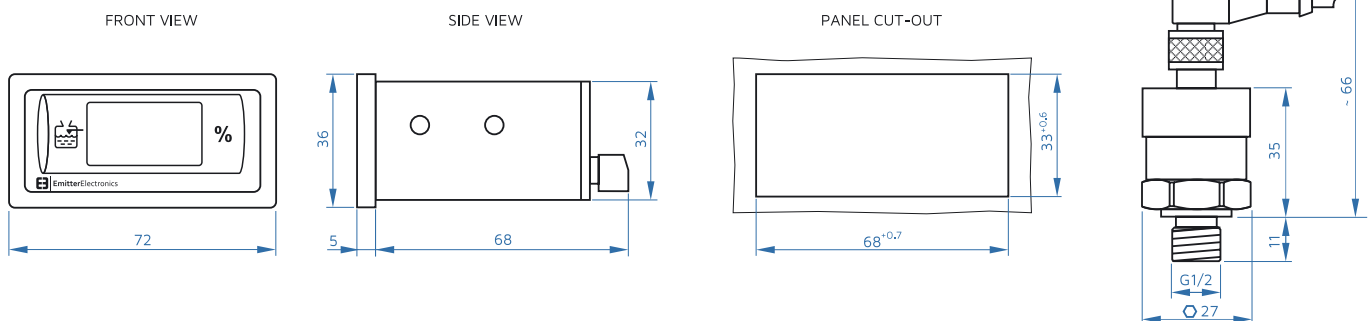

Optional I/O driver can be integrated for low level warning output, autofill-hysteresis output, mute input, etc.

The Tank Level Gauge can be used as a stand-alone system or as a part of MMX system connected via CAN bus to IO Controller. Several

slave indicators (small remote - RIS) can be connected to a master indicator INS to show the same value on different locations or in combination with a XL remote indicator (RIXL) for the vehicle sides.

Connection

CONNECTION standard device

PIN	DESCRIPTION
1	BATTERY + (*15")
2	BATTERY -
3	OUT1 (OPTIONAL)
4	T-COMMUNICATION
5	SENSOR [V] GND
6	SENSOR [V]/[mA] SIGNAL
7	SENSOR [V]/[mA] VCC+
8	OUT2 (OPTIONAL)
9	OUT3 (OPTIONAL)
10	OUT4 (OPTIONAL)
11	OUT5 (OPTIONAL)
12	OUT6 (OPTIONAL)
13	OUT7 (OPTIONAL)

CONNECTION CAN bus device

PIN	DESCRIPTION
1	BATTERY + (*15") / SENSOR SUPPLY (OPTIONAL)
2	BATTERY - / SENSOR GND (OPTIONAL)
3	OUT1 (OPTIONAL)
4	T-COMMUNICATION / OUT3 (OPTIONAL)
5	IN1
6	SENSOR [V]/[mA] SIGNAL
7	OUT2 (OPTIONAL)
8	SENSOR [V]/[mA] VCC+ / OUT4 (OPTIONAL)
9	OUT5 (OPTIONAL)
10	SENSOR [V] GND / OUT6 (OPTIONAL)
11	OUT7 (OPTIONAL)
12	CAN L
13	CAN H

Transducer-OEM

SPECIFICATION AND CONNECTION

Pressure Range	0-600 mbar (0 - 6 m tank height)
Signal Output	0.5-4.5 V
IP Class (IEC529)	IP67
Transducer Material	Stainless steel 316L
Pressure Port	1/4"
Transducer Cable	3 x 0.35 mm ² with M12 connector
M12 Connection	1:Ub, 3:GND, 4:Signal+

Specifications

POWER	
Supply Voltage	9-30 V DC
Current	0.5 A maximum, no outputs active
Electrical Protection	overvoltage, transients, reverse polarity
INTERFACES	
CAN	1 x CAN, optional
CAN termination	120 ohm, solder pad on PCB
Serial communication	1 x T (1 Wire), optional
I/O	
Sensor input	0.5-4.5 V Standardly, 0-5V, 0-10V, 4-20 mA
Digital Input	GND, only with CAN bus device
Digital Output	<i>*Only version with integrated I/O driver</i>
OUT1	positive switching (relay), max. 6 A (Low water warning)
OUT2	positive switching (relay), max. 1.5 A (Autofill-Hysteresis)
OUT3-OUT7	negative switching (low-side), max. 1.8 A (large light driver)
Loads	inductive, resistive

ENVIRONMENT	
IP Class (IEC529)	front panel IP67, back IP20
EMC Conformity	EN61000-6-2 noise immunity EN61000-6-4 radiation of interference
Temperature Range	storage -40° to +85°C (-40° to 185°F) operating -40° to +85°C (-40° to 185°F)
ENCLOSURE	
Housing Material	NORYL with glass-fibre reinforcement
Mounting	in-dash, with clips or springs
Connector	Terminal block 4, 8 or 13 way depending on selected options
MISCELLANEOUS	
Indicator increments	1/20 (5%)
Day/Night operation	automatic - integrated light sensor
Front panel	backlit, colour coded for water and foam
Detectable substances	water, fire-smothering foam, gasoline, etc
SIZE AND WEIGHT	
W x H x D	36 x 72 x 68 mm with connector
Weight	0.1 kg

How to order (use characters in bold to create order code)

SET of master indicator small INS, sensor PT06-U4, sensor cable

Ordering code example:

T	L	G	S	-	2	O	W	T	-	O	5	R	H	L	
20 DISPLAY INCREM. 1/20 (5%)		W: WATER F: FOAM		T: 1 WIRE C: CAN BUS		CABLE LENGTH, METERS (INCH) 05: 5 M (20") 10: 10 M (40") 15: 15 M (60")		OUT1 R: LOW LEVEL WARNING		OUT2 H: AUTOFILL HYST. xx/xx % R: ADD. OUTPUT		OUT3, OUT4 L: LLD5 DRIVER 5X1.8A GND OUTPUTS		IN1 NEGATIVE M: MUTE OUT1 (only CAN device)	

Remote Indicator - Small

Ordering code example:

R	I	S	-	2	O	W	T	O	-	R	H				
20 DISPLAY INCREM. 1/20 (5%)		W: WATER F: FOAM		T: 1 WIRE C: CAN BUS		LED BRIGHTNESS I: INSIDE O: OUTSIDE		OUT1 R: LOW LEVEL WARNING		OUT2 H: AUTOFILL HYST. xx/xx % R: ADD. OUTPUT		OUT3, OUT4 L: LLD5 DRIVER 5X1.8A GND OUTPUTS		IN1 NEGATIVE M: MUTE OUT1 (only CAN device)	

Master Indicator - Small

Ordering code example:

I	N	S	-	2	O	W	T	U	4	R	H	L	M		
20 DISPLAY INCREM. 1/20 (5%)		W: WATER F: FOAM		T: 1 WIRE C: CAN BUS		SENSOR INPUT / PROBE U4: 0,5-4,5V U1: 0-10 V I2: 4-20 MA		OUT1 R: LOW LEVEL WARNING		OUT2 H: AUTOFILL HYST. xx/xx % R: ADD. OUTPUT		OUT3, OUT4 L: LLD5 DRIVER 5X1.8A GND OUTPUTS		IN1 NEGATIVE M: MUTE OUT1 (only CAN device)	



EMITTER ELECTRONICS

Engineering, production and service
Tržaška cesta 65, SI-2000 Maribor, Slovenia, Europe

Phone +386 5 995 1 973
mobile +386 41 726 476

info1@emitter.org
www.emitter.org

