

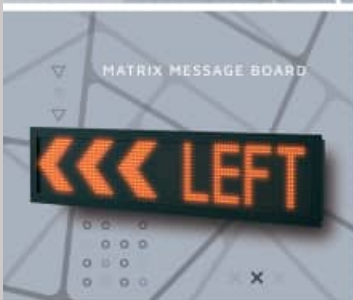

EMITTER 2025.04 ELECTRONICS

MMX
SYSTEM



INNOVATIVE, RELIABLE, FLEXIBLE

AUSTRALIA • DENMARK • NORWAY • AUSTRIA • GERMANY
HUNGARY • PORTUGAL • BELGIUM • LITHUANIA • ITALY • FRANCE
POLAND • NETHERLANDS • SLOVENIA • CZECH REPUBLIC • PAKISTAN
IRELAND • GREECE • UNITED KINGDOM • SOUTH AFRICA • CROATIA
FINLAND • UAE • UKRAINE • EGYPT • TAIWAN • SAUDI ARABIA
SINGAPORE • INDONESIA • TURKEY • INDIA

New Edge of Electronic Instruments and Controls

www.emitter.org

WE DELIVER EXPERIENCE AND QUALITY SINCE 1990

EMITTER electronics is a technically driven design and manufacturing company dedicated to helping customers to solve their toughest electronics, automation, sensing and measurement problems.





A flexible manufacturing system allows us quick responsiveness as well as efficient handling of large blanket orders. Our products can easily be integrated into already existing systems or can be specially designed for different applications.

Emitter engineering team can help you to design an advanced control system, custom device or modify existing products to save your labour and assembly costs to be more competitive on the market. We have maintained a competitive advantage in this area by being always available to all our customers and potential clients.

Quality, responsibility and innovation have been the fundamental mottos of our operations since the very establishment of the company.



CONTENT

MMX C1  06	MMX RGB 96x16  10	PAS 100/200  12	MMX GNSS/GPRS  16
--	---	--	---

INTERCOM  18	PUMP CONTROL UNITS  20-26
--	---

PCU-PG	20
PCU-WPG	22
PCU-WFPG	24
PCU-WKPG	26

KEYBOARDS  28-38	KPM-G21 28 KPM-G26 30 KPM-G22J2 32 KPM-C22 34 KPM-C24 36 KPM-C26 38
--	--

LCD HMI DEVICES  40-44	MMX LCD4K5 40 MMX LCD7 42 MMX LCD10 44
---	--

S&L MONITORS  46
--

TANK LEVEL GAUGES  48-54	Tank Level Gauge RTS Small, RTSS 48 Tank Level Gauge TLG Small, TLGS/INS/RIS 50 Tank Level Gauge TLG Large, TLGL/INL/RIL 52 Tank Level Gauge TLGS 20 54
--	--

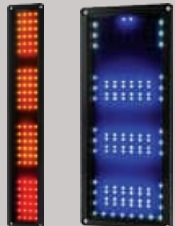
XL REMOTE INDICATORS  56-58	XL Remote indicators narrow, RIXLN 56 XL Remote indicators wide, RIXLW 58
---	--

DIGITAL PRESSURE INDICATOR  60

PRESSURE SENSORS  64
--

FLASHER  66

PTO TIMER  67

MODULAR MULTIPLEX SYSTEM - MMX



Features and Benefits

- 1 Simplifies wiring Harness. Reduces the number of wires by more than 40%, that means 40% fewer possible failure points
- 2 Eliminates most of Fuses & Relays
- 3 Fewer parts and easy diagnostics resulting in fewer efforts for maintenance time. Because the system is simple, customisation and options can be done in software only, no hardware change needed.
- 4 Increases Diagnostic capabilities
- 5 Increases vehicle reliability
- 6 Integrates electrical & Electronic system

Vehicle wiring networks are rapidly becoming very complex due to increased usage of electronic controls, displays and features. As a result, the vehicle wire harness is growing in size and complexity to the point where multiplexing and data communication links are expected to be required to develop cost efficient and reliable vehicle systems.

Conventional wiring systems use separate wires to control each electrical function. The multiplex wiring system allows multiple electronic messages to travel

back and forth through the same datalink wire, just as broadband cable allows telephone, television and Internet connections to travel through the same line.

The MMX IO node controller sends information back and forth, monitoring vehicle components and interpreting messages transmitted through the wires. Because the modules are remotely controlled by signals, rather than by separate wires, fewer relays and connectors are required, reducing possible failure points.

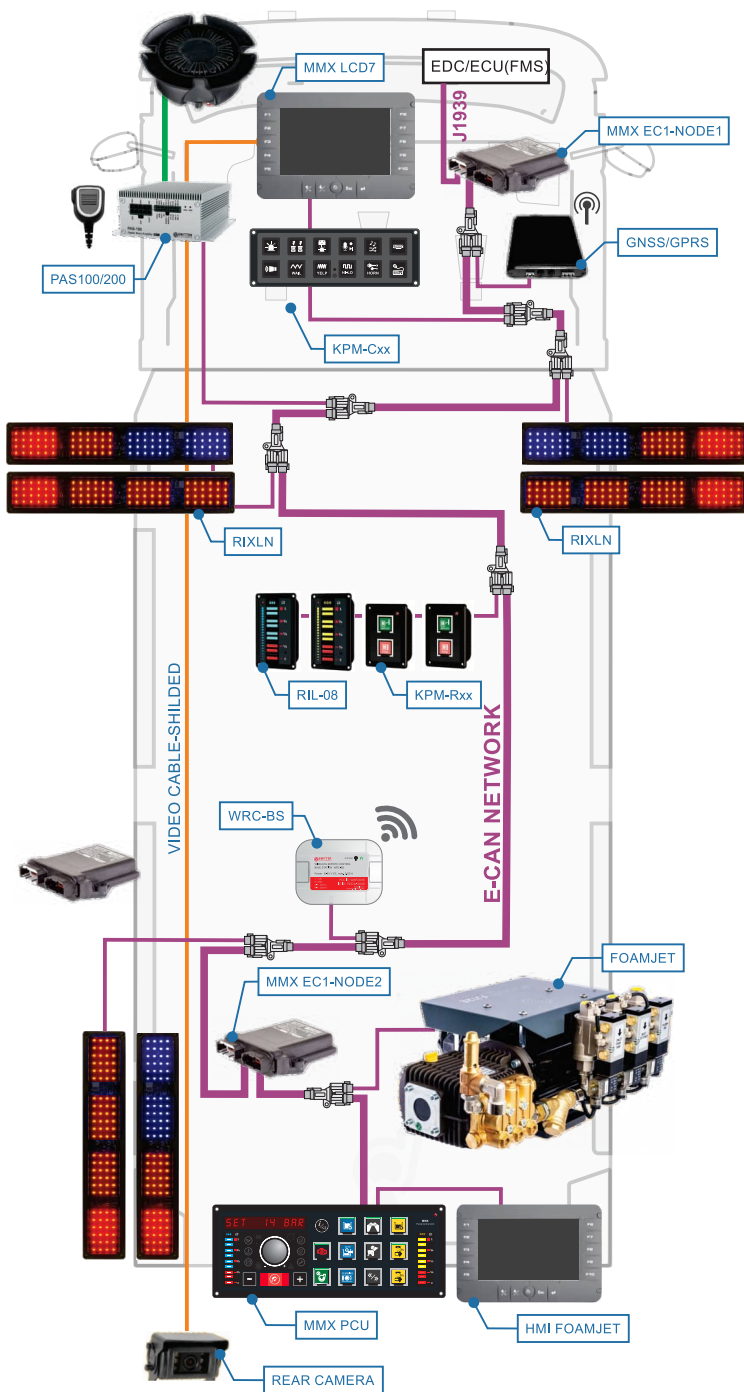

Example 1

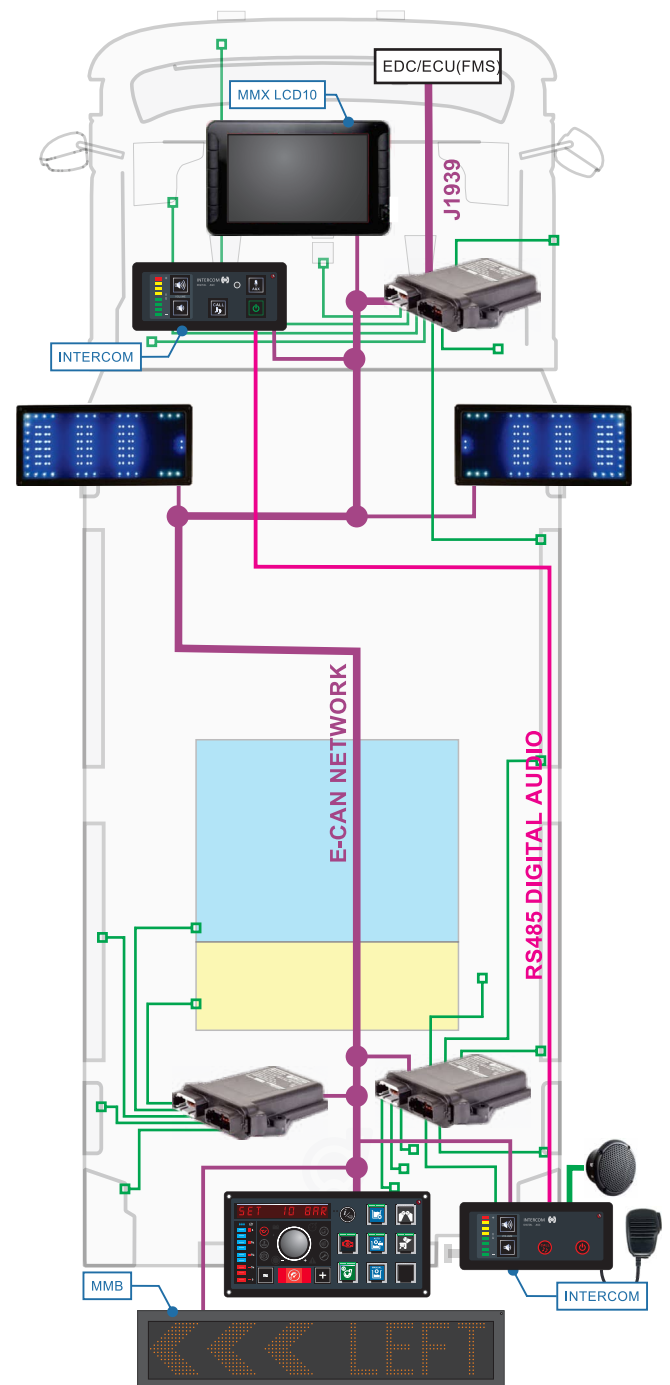

Example 2

MMX EC1 G6 CONTROLLER



Features and Benefits

- 1 **16 Universal Pins**
- 2 **Digital, Analog, Resistance Or Frequency Inputs**
- 3 **High Side, Low Side Or PWM Outputs**
- 4 **Data Logger**
- 5 **3-axis Accelerometer**
- 6 **I/O Status LEDs**
- 7 **Extension Options: H-Bridge, IMU, DAC, RS232/485, Etc.**

The MMX EC1 is a highly configurable controller which is designed for use in various automotive and industrial applications. It provides smart solutions for special vehicles, machinery, industrial automation and enables simple connectivity for sensors, switches, actuators and different CAN devices.

MMX EC1 is a part of Emitter Electronics MMX family products and can be used with other MMX family devices such as LCDs, keypads, pump governors, tank level indicators, etc. For applications requiring high I/O count, several MMX EC1 controllers can be connected over Can bus, CAN SAE J1939, CAN open or free protocol. MMX EC1 controllers are programmable in C/C++ language.

CONNECTIONS

Black Connector: Pin Description					
PIN	TYPE	OPTION 1	OPTION 2	OPTION 3	OPTION 4
1	FIXED	BATTERY +	-	-	-
2	FIXED	BATTERY +	-	-	-
3	FIXED	CAN LOW 1	-	-	-
4	CONFIGURABLE	CAN LOW 2 (J1939)	CAN LOW 1	-	-
5	CONFIGURABLE	ANALOG INPUT	DIGITAL INPUT +/-	DIGITAL OUTPUT+	-
6	CONFIGURABLE	ANALOG INPUT	DIGITAL INPUT +/-	DIGITAL OUTPUT+	-
7	CONFIGURABLE	ANALOG INPUT	DIGITAL INPUT +/-	DIGITAL OUTPUT+	RESISTANCE INPUT
8	CONFIGURABLE	ANALOG INPUT	DIGITAL INPUT +/-	DIGITAL OUTPUT+	-
9	CONFIGURABLE	CAN HIGH 2 (J1939)	CAN HIGH 1	-	-
10	FIXED	CAN HIGH 1	-	-	-
11	FIXED	BATTERY -	ANALOG GND	-	-
12	FIXED	BATTERY -	-	-	-

Grey Connector: Pin Description						
PIN	TYPE	OPTION 1	OPTION 2	OPTION 3	OPTION 4	EXTENSION BOARD
1	CONFIGURABLE	DIGITAL INPUT +/-	DIGITAL OUTPUT + PWM	-	-	-
2	CONFIGURABLE	DIGITAL INPUT +/-	DIGITAL OUTPUT + PWM	-	-	-
3	CONFIGURABLE	DIGITAL INPUT +/-	DIGITAL OUTPUT + PWM	-	-	-
4	CONFIGURABLE	DIGITAL INPUT +/-	DIGITAL OUTPUT + PWM	-	-	-
5	CONFIGURABLE	DIGITAL INPUT +/-	DIGITAL OUTPUT + PWM	DIGITAL OUTPUT -	-	EXTENSION A
6	CONFIGURABLE	DIGITAL INPUT +/-	DIGITAL OUTPUT + PWM	DIGITAL OUTPUT -	-	EXTENSION A
7	CONFIGURABLE	DIGITAL INPUT +/-	DIGITAL OUTPUT + PWM	DIGITAL OUTPUT -	-	EXTENSION B
8	CONFIGURABLE	DIGITAL INPUT +/-	DIGITAL OUTPUT + PWM	DIGITAL OUTPUT -	RESISTANCE INPUT	EXTENSION B
9	CONFIGURABLE	DIGITAL INPUT +/-	DIGITAL OUTPUT + PWM*	DIGITAL OUTPUT -	-	EXTENSION C
10	CONFIGURABLE	DIGITAL INPUT +/-	DIGITAL OUTPUT + PWM*	DIGITAL OUTPUT -	-	EXTENSION C
11	CONFIGURABLE	DIGITAL INPUT +/-	DIGITAL OUTPUT + PWM*	DIGITAL OUTPUT -	-	-
12	CONFIGURABLE	DIGITAL INPUT +/-	DIGITAL OUTPUT + PWM*	DIGITAL OUTPUT -	-	-

BLOCK DIAGRAM

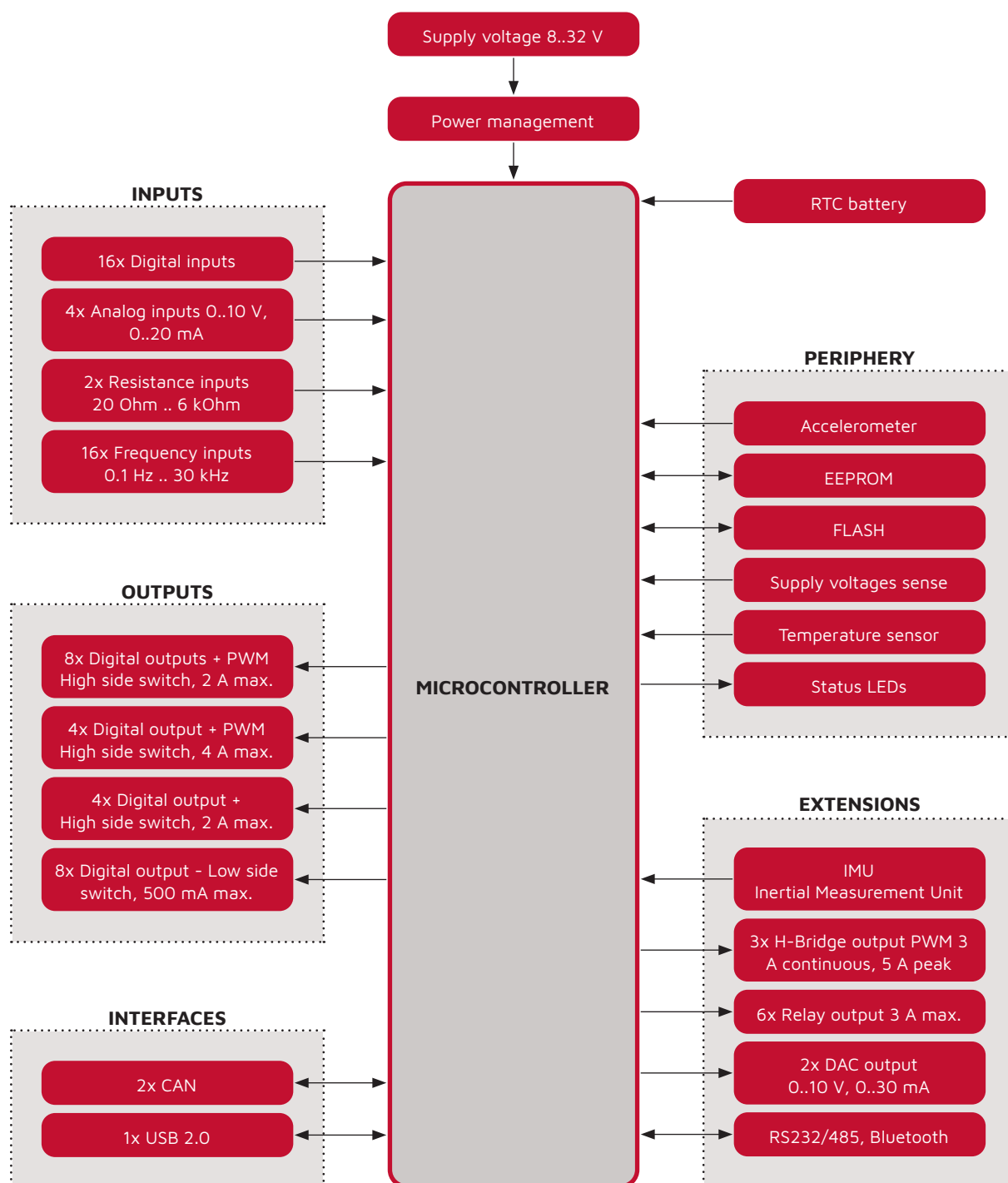

NOTE: Block diagram shows all available MMX EC1 G6 controller inputs and outputs - 16 of them can be used simultaneously (MMX EC1 G6 controller has 16 configurable IO pins).

MMX EC1 G6 CONTROLLER

SPECIFICATIONS

KERNEL	
Processor	32-bit ARM Cortex-M4, 168 MHz
Processor flash	1 MByte
Processor RAM	192 kByte
External EEPROM	2 kByte
External flash	64 MByte
I/O PINS	
Total	16x universal pins, individually configurable via software, all I/O pins are protected against short circuit to GND and BAT +, each I/O pin is diagnosable via status LEDs
INPUTS	
Digital input	16x total, configurable integrated pull-up/down resistor and active low/high levels via software, protected
Analog input	4x total, 12-bit resolution, configurable voltage/current input via software, 4 .. 20 mA, 0 .. 10 V, out-of-range detection, protected
Resistance input	2x total, 12-bit resolution, 20 Ohm .. 6 kOhm, Pt1000, Pt100, KTY support, protected
Frequency input	16x total, ≤ 30 kHz, incremental encoder A/B - 8x total, protected
OUTPUTS	
Digital output + PWM	8x total, high side switch, 2 A max., 0 .. 100 %, overload/short circuit protection, overtemperature protection, open load detection
Digital output + PWM (high current)	4x total, high side switch, 4 A max., 0 .. 100 %, overload/short circuit protection, overtemperature protection, open load detection
Digital output +	4x total, high side switch, 2 A max., overload/short circuit protection, overtemperature protection, open load detection
Digital output -	8x total, low side switch, 500 mA max., overload/short circuit protection, overtemperature protection, open load detection
DAC output	2x total, 12-bit resolution, available via extension board
Voltage DAC	0 .. 10 V (10mA)
Current DAC	0 .. 30 mA
INTERFACES	
CAN	2x CAN, ISO 11898 2.0 A/B up to 1 Mbps, protocols SAE J1939, CANopen, free, etc.
CAN Link	1x T-connection, configurable termination 120 ohm via DIP switch, node ID definition via software
USB	1x USB 2.0, for firmware update
RS232/485, Bluetooth, ...	available via extension boards

OTHER FEATURES	
Accelerometer	integrated 3-axis, MEMS, 12-bit digital accelerometer, +/-2, +/-4, +/-8 g, for inclination/acceleration sensing
IMU	3-axis accelerometer 12-bit, measurement ranges ±2 g, ±4 g, ±8 g, ±16 g, resolution 0.98 mg, 3-axis gyroscope 16-bit, ±125 °/s, ±250 °/s, ±500 °/s, ±1000 °/s, ±2000 °/s, resolution 0.004 °/s, 3-axis magnetometer 16-bit, ±1300 μT (x,y), ±2500 μT (z), resolution 0.3 μT, available via extension board
Data logger	system information/data logging, optional RTC logging with dedicated 1000 mAh onboard battery
Monitoring	internal monitoring of power supply voltage, RTC battery voltage, CPU core temperature and board temperature, over/under supply voltage detection, watchdog functionality
LED diagnostics	dedicated on board status LEDs for I/O pin diagnostics and error indication
Protections	overvoltage, transients, load dump protection, reverse polarity protection by external fuse
ELECTRICAL & ENVIRONMENTAL REQUIREMENTS	
Supply voltage	8 .. 32 V
Peak supply voltage	≤ 36 V for ≤ 5 min, ≤ 40 V for ≤ 2 s
Idle current	30 mA @ 24 V
Max total current	15 A
RTC battery life	min. 10 years
Operating temperature	-40 .. +85 °C (with full load)
ENCLOSURE	
Connector	2x 12 pin Deutch DTM connector, waterproof
Ingress Protection	EN 60529 IP67
Housing material	Nylon 6/6 black glass fibre reinforced, silicone rubber
Housing dimensions	133 x 119 x 35 mm
Weight	250 g
SOFTWARE	
Programming environment	C/C++, high level API-library included
STANDARDS	
CE-Mark	2014/30/EU
E-Mark	ECE 10 R-06 noise immunity with 100 V/m
EMC	EN 61000-6-2, noise immunity EN 61000-6-4, radiation of interference
Electrical	ISO 7637-2, pulse immunity, load dump

DIMENSIONS

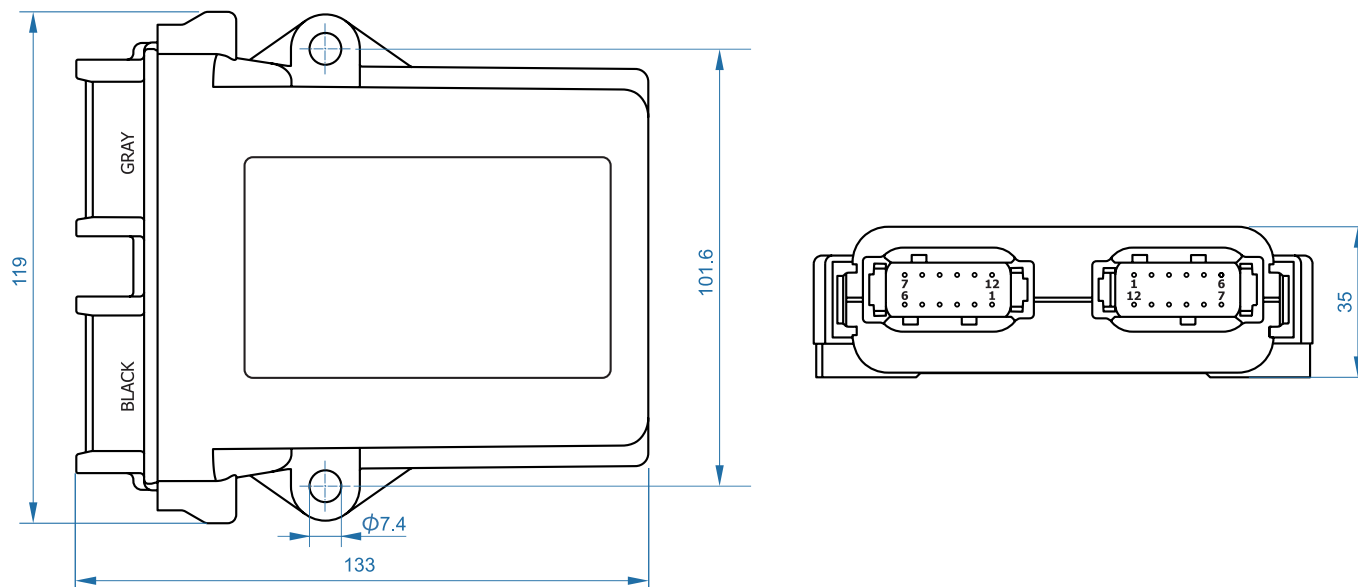

PRODUCT CODE

Product Code	Total IO	OUT+	OUT+*	OUT-	IN+	IN-	AIN	RIN	F	B	CAN Configuration	EXT1	EXT2	EXT3	Type	Status
MMXEC1-0000-xxxx	16	0	0	0	16	16	4	2	-	-	DIP Switch	-	-	-	TBD	Preview
MMXEC1-0400-xxxx	16	4	0	0	16	12	4	2	-	-	DIP Switch	-	-	-	TBD	Preview
MMXEC1-0600-0012	16	6	2	0	16	10	4	2	-	-	DIP Switch	-	-	-	Standard	Active
MMXEC1-0800-xxxx	16	8	4	0	16	8	4	2	-	-	DIP Switch	-	-	-	TBD	Preview
MMXEC1-1000-xxxx	16	10	2	0	16	6	4	1	-	-	DIP Switch	-	-	-	TBD	Preview
MMXEC1-1200-0013	16	12	4	0	16	4	4	1	-	-	DIP Switch	-	-	-	Standard	Active
MMXEC1-1600-xxxx	16	16	4	0	16	0	0	0	-	-	DIP Switch	-	-	-	TBD	Preview
MMXEC1-1200-0014	16	6	2	6	10	10	4	1	-	-	DIP Switch	-	-	-	Special	Active

*High current outputs

**CAN1 and CAN2 120Ω termination resistors are connected by zero-ohm resistors

OUT - Output, IN - Input, AIN - Analog input, RIN - Resistance input, F - Flash, B - Battery, EXT1 - Extension 1, EXT2 - Extension 2, EXT3 - Extension 3

For other possible IO configurations please contact the supplier.

MATRIX MESSAGE BOARD

MMB-RGB 96X16



Features and Benefits

- 1 Full-Matrix RGB LED Display
- 2 96 x 16 Pixels for Clear Message Presentation
- 3 Text, Arrows, Signs, Warnings Patterns
- 4 Long Message presentation - Scroll or Push Transitions
- 5 Unique In-Dash Mounting
- 6 CAN Bus

The Matrix Message Board **MMB-RGB 96x16** is mainly designed to be mounted on special vehicles to warn or direct traffic, provide information and to secure danger spots on streets or in public areas. The patterns, such as text, arrows and signs are pre-programmed according to the customers needs as well as the colour of the pattern itself. Default colour is amber.

The in-dash mounting of the MMB is unique on the market. The board is practically installed flat with the vehicles side to give it a modern look.

The MMB is a part of Emitter Electronics MMX family products and can be controlled by MMX LCD units, keypads or used together with customers CAN bus system.

Black coated aluminium housing and UV protected polycarbonate front plate are made for long lasting operation and are highly resistant to all weather conditions.



SPECIFICATIONS

POWER

Unit Supply Voltage 8-32 V DC

Current max. 0.7 A @ 24 V
max. 1.4 A @ 12 V

Electrical Protection overvoltage, transients, reverse polarity, load dump

INTERFACES

CAN 1x CAN, ISO 11898 2.0 A/B up to 1 Mbps, protocols SAE J1939, CAN open, free, etc.
CAN Termination 120 Ohm, DIP switch

LED MATRIX

LED matrix 96x16 RGB super bright SMD LEDs

Message presentation arrows, text, signs and other patterns

Message animation steady, scroll, push

Light sensor optional

ENVIRONMENT

Temperature range storage from -40°C to +85°C

Storage Temperature operation from -40 to +85°C

IP Class (IEC529) IP65, front panel IP67

EMC designed to EN 61000-6-2, noise immunity
designed to EN 61000-6-4, radiation of interference

ENCLOSURE

Matting Connector Deutsch DT06-06S, automotive 6-way connector, waterproof

Housing material Aluminium housing - black coated, polycarbonate front plate - transparent

Housing dimensions transparent protection plate, 1023 x 221 x 56 mm

Mounting in-dash with 6 screws M5 or tapping screws with max. diameter of 5 mm

SIZE AND WEIGHT

W x H x D 1023 x 221 x 56 (34 without connector)

Weight 4 kg

DIMENSIONS

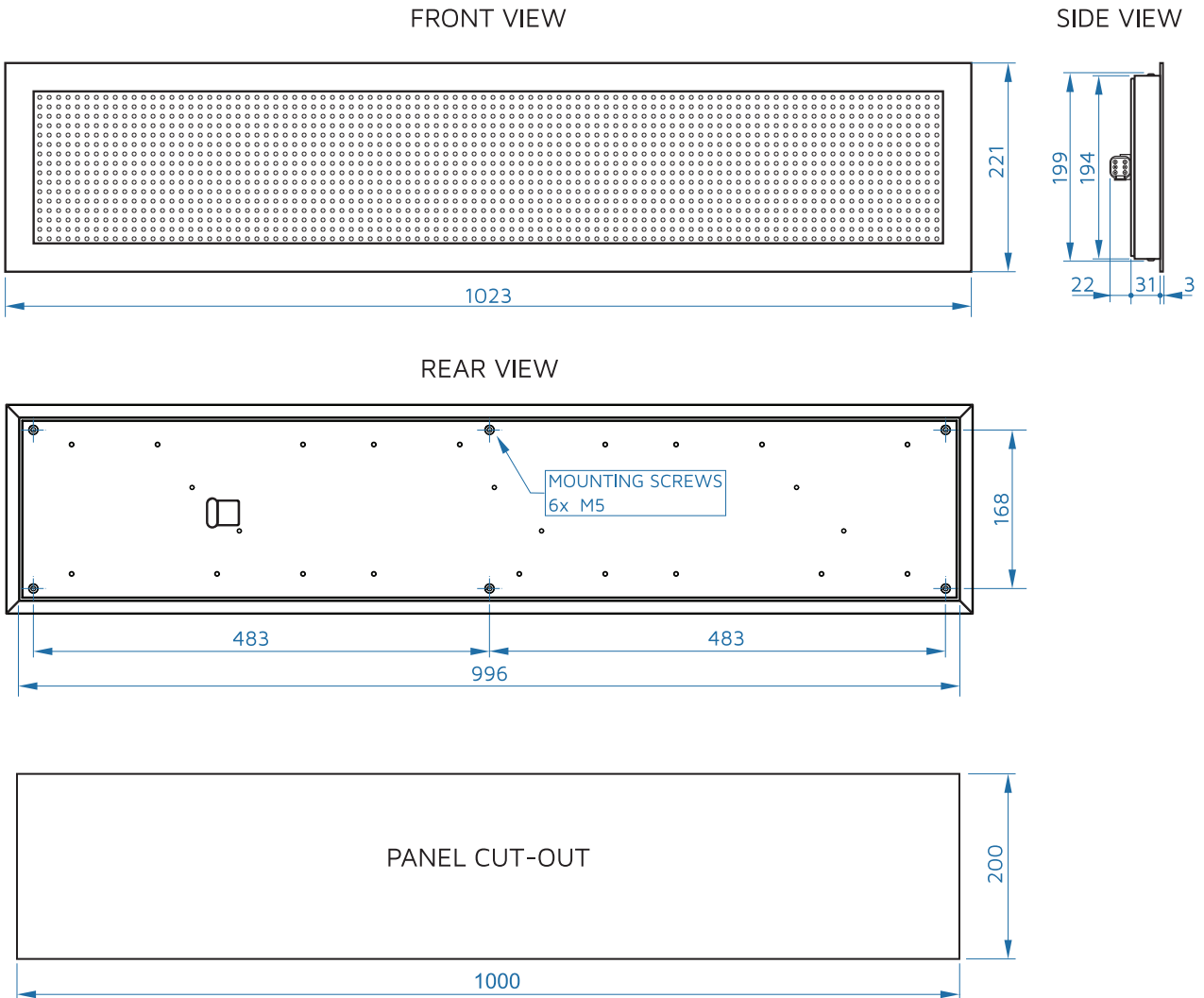

CONNECTIONS

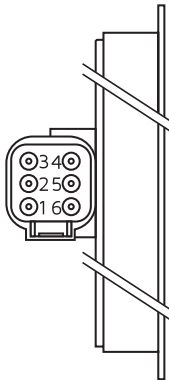

Deutsch DT06-6S

PIN DESCRIPTION

PIN	DESCRIPTION
1	Battery +
2	CAN L
3	CAN L, internal shorted to pin 2
4	CAN H
5	CAN H, internal shorted to pin 4
6	GND (Battery -)

PRODUCT CODE

MMB-RGB 96X16 matrix message board, 96x16 px, RGB, CAN

Standard

Active

For more options please contact the supplier.

PAS 100 / 200

DIGITAL SIREN AMPLIFIER

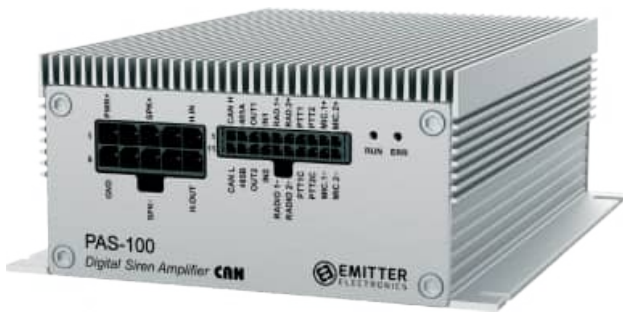

Features and Benefits

- 1 Power Amplifier with PA system
- 2 True RMS 100 W or 200 W (2x100 W)
- 3 Multi-voltage 8-32 VDC
- 4 Record'n'Play Function, optionally
- 5 Horn Ring Cycler
- 6 Full CAN Bus Control

The PA electronic Siren Amplifier **PAS-100/200** is designed to be used in Emergency vehicles such as ambulance, firefighting, police or other law enforcement vehicles. The amplifier is available in 100 W and also in 200 W version with two independent channels of 2x 100 W True RMS. It can provide a wide range of pre-programmed siren sounds that can be set according to the different country regulations and market needs. Incorporates radio broadcast - two radio inputs and PTT handheld unit with a public access (PA) override function - two mic. inputs.

The siren sound can also be changed with the Ring horn button - Horn Ring Cycler function. It has an integrated OEM Horn Ring transfer Relay and load simulation resistor to avoid problems of displaying errors on vehicle's dashboard when the OEM Horn wire is cut. Optionally it can be supplied with extended memory used for Record'n'Play function. For additional functions, two digital high side outputs and inputs are available.

The PAS100/200 amplifier is a part of Emitter Electronics MMX family products and can be controlled by MMX LCD units, keypads or used together with customers CAN bus system.

As a special function, the Amplifier can transfer the sound via RS485 to other devices E.g. Intercom system etc



SPECIFICATIONS

POWER	
Supply Voltage	8-32 V DC
Current	<50 mA @ IDLE
PAS-100	max. 15 A + dig. outputs @ 12 V max. 7.5 A + dig. outputs @ 24 V
PAS-200	max. 30 A + dig. outputs @ 12 V max. 15 A + dig. outputs @ 24 V
Electrical Protection	Overvoltage, under-voltage, transients, reverse polarity by breaking external fuse, load dump, over-temperature
INTERFACES	
CAN	1x CAN, ISO 11898 2.0 A/B up to 1 Mbps, protocols SAE J1939, CAN open, free, etc. Baud rate 250 kbps (optional ≤ 1 Mbps)
CAN Termination	120 Ohm, configurable with internal DIP switch
El. Protection	Short to GND or Ub, allowable voltage on pins 0..32V
RS485	TIA/EIA 485, used for audio transfer, Baud rate ≤ 1 Mbps, optional
RS485 Termination	120 Ohm, DIP switch
El. Protection	Short to GND or Ub, allowable voltage on pins 0..32V
AUDIO I/O	
Inputs	
Microphone Level Input	2 x, differential or single ended input, 100 Hz .. 10 kHz @-3dB
PTT (Push To Talk) Input	2 x, active low logic, integrated pull-up resistor
Speaker/Line Level Input	2 x, differential or single ended input, 100 Hz .. 10 kHz @+3dB
Outputs	
Speaker Output PAS-100	1 x, RMS output power 100 W/ch @11 Ω, 100 Hz .. 10 kHz @-3dB
Speaker Output PAS-200	2 x, RMS output power 100 W/ch @11 Ω, 100 Hz .. 10 kHz @-3dB
El. Protection	Overload – short between pins, short to GND or Ub, over temperature
DIGITAL I/O	
Inputs	2 x, active high logic, integrated pull-down resistor
El. Protection	Short to GND or Ub, allowable voltage on pins 0..32V
Outputs	2 x, high side switch ≤ 2.2 A
El. Protection	Overload – short between pins, short to GND or Ub, over temperature
OEM HORN CONTROL	
Relay	Integrated, normally open contacts, 24 V:I ≤ 15 A, 12 V:I ≤ 30 A
OEM Horn Input	Voltage sensing, pull-down (optional pull-up) load simulation resistor

MISCELLANEOUS	
LED Diagnostics	1x green run LED on front panel, 1x red error LED on front panel
Monitoring	Internal sensing of supply voltages, CPU core and board temperature, watchdog functionality
ENVIRONMENT	
Temperature range	
Storage	From -40°C to +85°C
Operation	Ambient from -40 to +65°C, internal -40 to +105°C (at full load)
IP Class (IEC529)	IP2x
EMC	Designed to EN 61000-6-2, noise immunity Designed to EN 61000-6-4, radiation of interference Designed to ISO 7637-2 pulse immunity, load dump Designed to ECE-R10.5 noise immunity

ENCLOSURE	
Matting Connector	
Power Connector	Mega Fit 10-way dual row for cables 2.5 mm ² (14 AWG)
Signal Connector	WR-MPC3 20-way dual row for cables 0.5 mm ² (24-20 AWG)
Housing material	Aluminium housing - anodised
Mounting	4 screws M4 or tapping screws with max. diameter of 4.5 mm
SIZE AND WEIGHT	
Housing dimensions	W x H x D
PAS-100	105 x 48 x 160 mm
PAS-200	105 x 48 x 220 mm
Weight	
PAS-100	0,8 kg
PAS-200	1,1 kg

Block Diagram of all available amplifier functions:

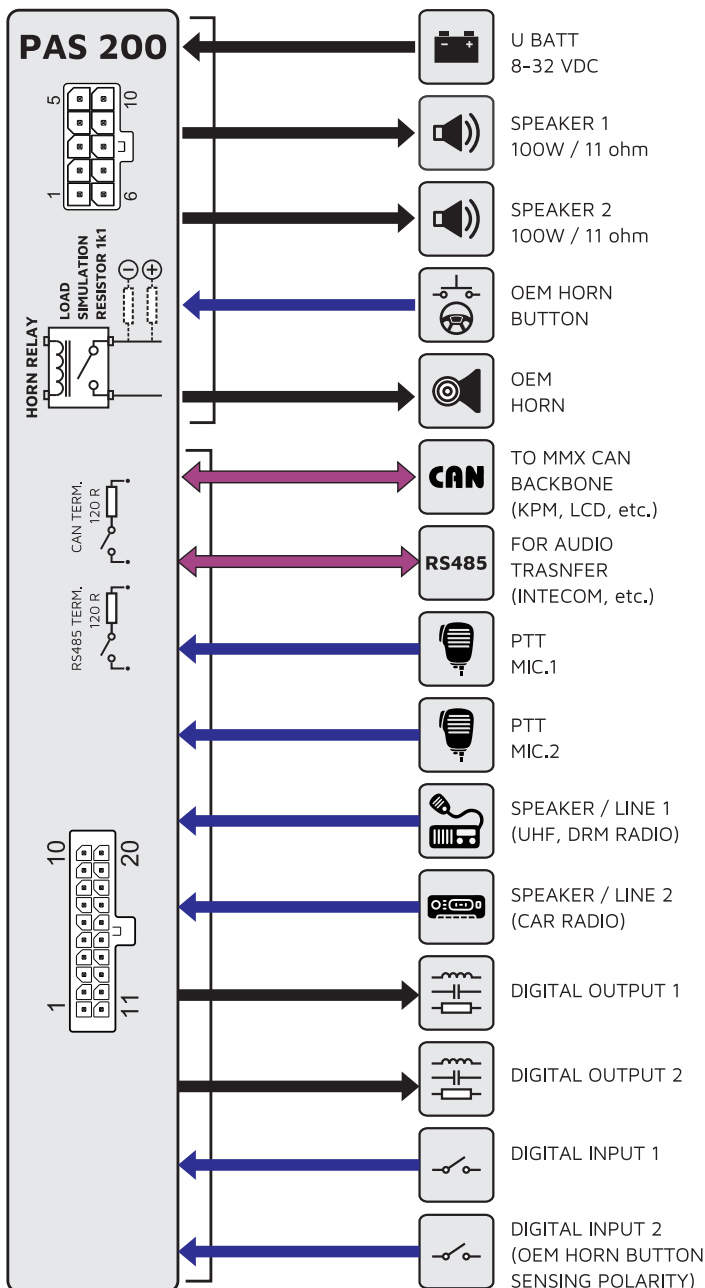

POWER CONNECTOR Mega-Fit 2x5

PIN DESCRIPTION

1	Battery +
2	GND (Battery -)
3	Speaker 1 Out +
4	Speaker 2 Out +
5	OEM Horn In
6	Battery +
7	GND (Battery -)
8	Speaker 1 Out -
9	Speaker 2 Out -
10	OEM Horn Out

SIGNAL CONNECTOR WR-MPC 2x10

PIN DESCRIPTION

1	CAN H
2	RS485 A
3	Digital Output 1
4	Digital Input 1
5	Speaker/Line Input 1 +
6	Speaker/Line Input 2 +
7	Microphone PTT 1 Input
8	Microphone PTT 2 Input
9	Microphone Input 1 +
10	Microphone Input 2 +
11	CAN L
12	RS485 B
13	Digital Output 2
14	Digital Input 1
15	Speaker/Line Input 1 -
16	Speaker/Line Input 2 -
17	Microphone PTT 1 GND
18	Microphone PTT 2 GND
19	Microphone Input 1 -
20	Microphone Input 2 -

PAS 100 / 200 DIGITAL SIREN AMPLIFIER

DIMENSIONS

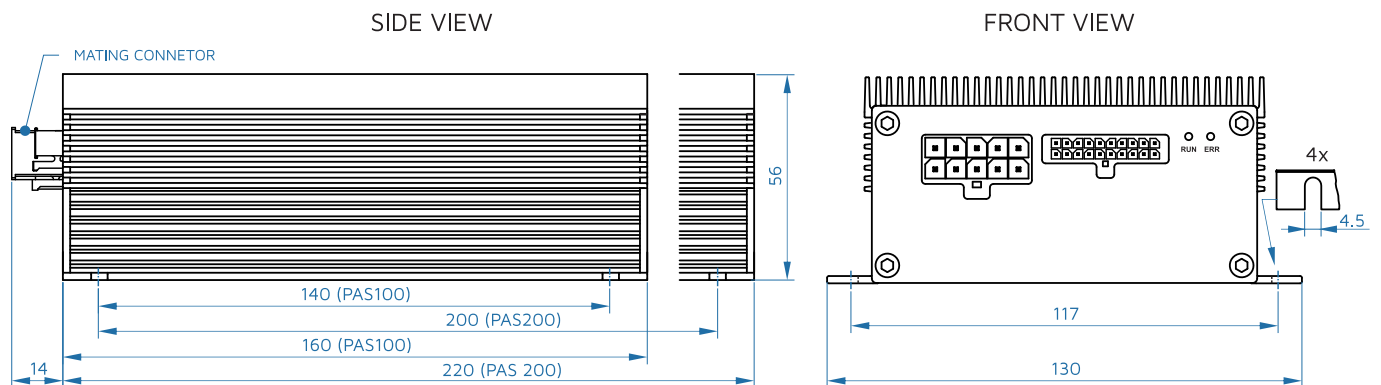

HANDHELD MIC UNITS

Product Code	Description	Picture	Status
HH-MIC1E-XLR-01	Handheld mic., electret condenser, PU coiled cable 0.5m, 5x0.8 mm ² with XLR connector		Standard

PRODUCT CODE

Product Code	Description	Status
PAS-100S	PA Siren Amplifier, Power 100W/11 ohm, CAN, 8-32 VDC, Standard version	Active
PAS-100F	PA Siren Amplifier, Power 100W/11 ohm, CAN, 8-32 VDC, Full version (record'n'play, RS485)	TBD
PAS-200S	PA Siren Amplifier, Hi-Power 200W/11 ohm, CAN, 8-32 VDC, Standard version	Active
PAS-200F	PA Siren Amplifier, Hi-Power 200W/11 ohm, CAN, 8-32 VDC, Full version (record'n'play, RS485)	TBD

For more options please contact the supplier.

SIREN SPEAKERS

Three types of high-performance, heavy-duty siren speakers are available, designed to deliver clear voice reproduction and withstand extreme weather conditions. All models are fully compatible with Emitter Electronics siren amplifiers.

SPK -R100W11-01 Standard 100W speaker offering robust performance and reliability.

SPK-R100W11-02 A powerful, slim-profile 100W speaker with powerful acoustic performance delivering sound levels over 122 dB. Its compact design allows flexible installation options, including tight spaces such as under the vehicle hood.

SPK-R50W8LW-01 Specialized low-frequency 50W speaker, designed to be used in pairs and connected to a single audio channel on specific siren amplifiers. This configuration generates infrasound waves that penetrate solid objects, allowing both drivers and nearby pedestrians to physically feel the alert. Perfect for use in dense urban environments and high-traffic zones.

SPK-R100W11-01



FRONT VIEW

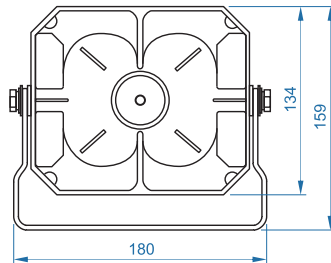

MOUNTING HOLES

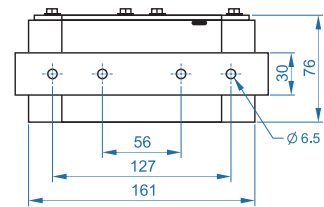

SPK-R100W11-02



FRONT VIEW

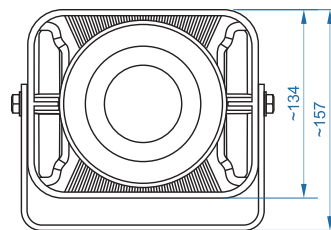

MOUNTING HOLES

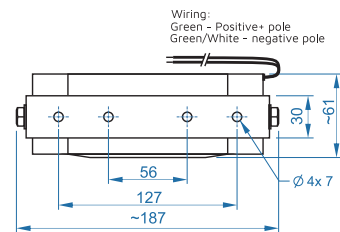

SPK-R50W8LF-01



FRONT VIEW

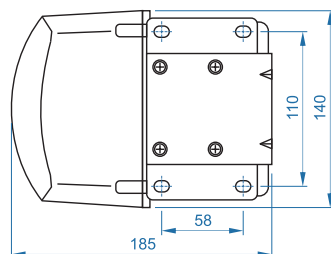

MOUNTING HOLES

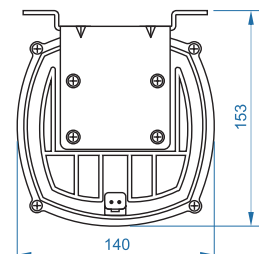

PRODUCT CODE

Product Code	Description
SPK -R100W11-01	Speaker PA 100 W, 11 Ohm, >118 dB, 200-5.000 Hz, ~3kg
SPK-R100W11-02	Speaker PA Super Thin 100 W, 11 Ohm, >122 dB, 200-5.000 Hz, ~3kg
SPK-R50W8LW-01	Speaker Low Frequency 50 W, 8 Ohm

For more options please contact the supplier.

MMX GNSS/GPRS MODEM



Features and Benefits

- 1 **Worldwide access to your vehicles or machines CAN data via the internet**
- 2 **Global navigation satellite system and cellular network for telematics services**
- 3 **Enables online access using any screen**
- 4 **Robust CAN hardware**
- 5 **Cloud-based and modern design Data Platform for powerful fleet management**
- 6 **Improves safety, efficiency and increases fleet visibility**

The Emitter telematic system consists of one or several CAN IO controllers (nodes) which collect telematic data from chassis and superstructure such as system and diagnostics data, vehicle CAN data etc, a GNSS/GPRS modem with integrated eSIM for tracking and sending the data to the cloud, cloud platform to store data for years, and a responsive web portal to visualize and act on the insights.

All sensors and actuators are connected to MMXEC1 I/O node. The I/O node communicates with GNSS modem via CAN bus.



SPECIFICATIONS

POWER

Supply Voltage 8-30 V DC

Current 1 A maximum

Current average at 24 V < 100 mA

Electrical Protection overvoltage, transients, reverse polarity via internal fuse

INTERFACES

CAN 1 x CAN

CAN termination no, use external resistor, CKIT DTM YT or similar

GNSS Professional Global navigation satellite system module, GPS, GLONASS, Galileo, BeiDou

GPRS HSPA/GSM 3G module, 3G bands 900/2100 Mhz and 2G bands 900/1800 Mhz

ENCLOSURE

Housing modem Aluminium

Mounting Inside the vehicle with cable ties

Mounting GNSS antenna Antenna has magnetic surface

Connector power supply Terminal block 2way

Connector CAN Terminal block 3way

Connector GNSS/GPRS SMA connector type

ENVIRONMENT

IP Class (IEC529) IP4x

EMC Conformity EN61000-6-2 noise immunity
EN61000-6-4 radiation of interference

Temperature Range storage -40° to +85°C (-40°F to 185°F)
operating -40° to +85°C (-40°F to 185°F)

MISCELLANEOUS

LED indicator 2x red/green for GNSS, CAN and Contact signal and server connection

Connectors Power and CAN: Terminal block 2way, 3way, GNSS and GPRS antenna: SMA connector

SIZE AND WEIGHT

W x H x D [mm] 109 x 106 x 30

Weight 0.3 kg with GNSS and GPRS antenna



GNSS/GPRS MODEM

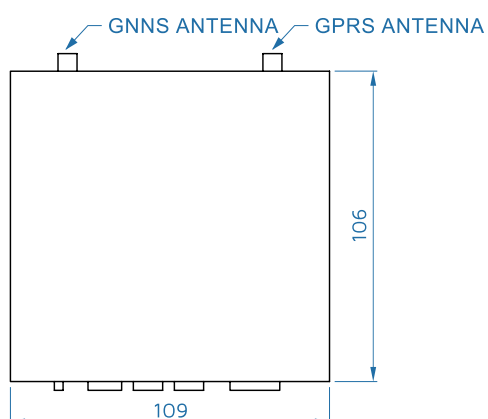
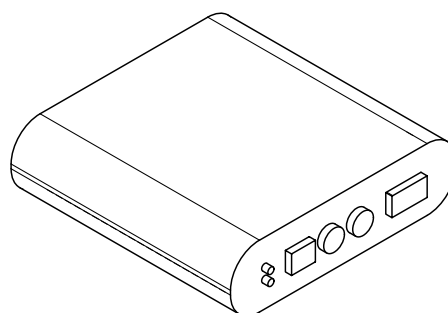
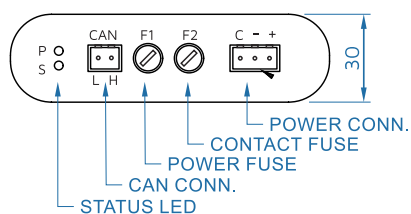

GNSS ANTENNA

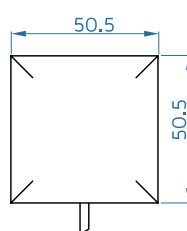
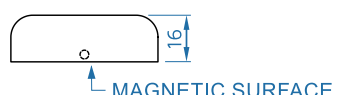

Real-time map

Scalable cloud-based platform collects and analyses data from connected vehicles and allows generating detailed and customized reports, actions, triggers and events to keep full control over your fleet. The interactive map is scalable and can be accessed from any device, such as PCs, notebooks, tablets, smartphones etc. View the current state of your engine and deep-dive into its historical data. Telematics data are based on a so-called "trip", a complete log from the moment a vehicle is turned ON until it's turned OFF again.



A log of records usually consists of:

GPS timestamp and location, GPS speed, GPS direction, vehicle status (ignition ON/OFF), vehicle voltage, driving and total working time, distance travelled, water and foam tank level, fuel level as well as digital or analogue IO status, RPM, Harsh acceleration, braking and cornering, etc. This offers you also a total control over the maintenance process of your fleet.

PRODUCT CODE

MMXGNSS GNSS/GSM modem with GPS and GSM antennas

For more options please contact the supplier.

INTERCOM



Features and Benefits

- 1 Digital audio processing and transmission
- 2 Automatic gain control (AGC)
- 3 Integrated microphone
- 4 RGB LED illuminated heavy-duty buttons, suitable for operation with protective gloves
- 5 Automatic Key brightness
- 6 Quick installation and setup
- 7 Robust e-coated aluminium enclosure

Supreme audio quality, Digital processing

Emitter Vehicle Intercom System is engineered to solve the problem of communication in high-noise environments such as in Fire and Rescue vehicles, mobile machines, ambulances, etc. The supreme audio quality is achieved with digital audio transmission which is much more immune to electrical noise and other disturbances than analogue transmission. Digital audio processing, automatic gain control (AGC), gate functionality and digital filtering improve sound quality on all levels.

INTERCOM consists of two main units and supporting components. Up to three slave units can be connected optionally. Regarding mounting location, one unit, usually mounted in the cabin, is marked as the "indoor/master unit" and the other one as the "outdoor/slave unit". Each unit has its own specific supporting components. The indoor/master unit has an integrated microphone, optional external gooseneck microphone and external 15 W speaker. The outdoor/slave unit has an external handheld unit with an integrated microphone and speaker, external 15 W speaker and 1 A output for external ring indication lamp or a buzzer.



SPECIFICATIONS

POWER

Supply Voltage 24 V version: 20-32 V DC
12 V version: 8-16 V DC

Current Consump. 24 V version: max. 1.5 A/unit
12 V version: max. 3.75 A/unit

Electrical Protection overvoltage, transients, reverse polarity, load dump

I/O AND INTERFACES

Output 1 x Current Sink Output, max. 1 A on outdoor/slave unit

Interfaces 1 x CAN, 1 x RS-485

Speaker 1 x RMS/PEAK power max. 15/25 W, 4 Ω

ENVIRONMENT

IP Class (IEC259) Indoor/MasterUnit IP53
Outdoor/Slave Unit IP67

Temperature Range Indoor/MasterUnit -20°C to +70°C
Outdoor/Slave Unit -40°C to +80°C

ENCLOSURE

Housing Material Aluminium

Mounting In-dash or out-dash with 4 screws M3 or 2.9 mm tapping screws

Matting connector Deutsch DT06-12S

Unit Weight 0.35 kg

INTERNAL STRUCTURE

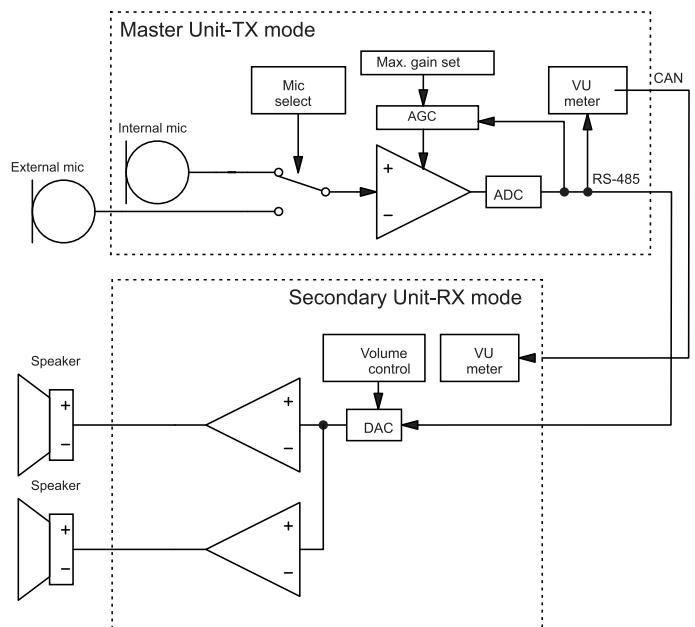



DIMENSIONS

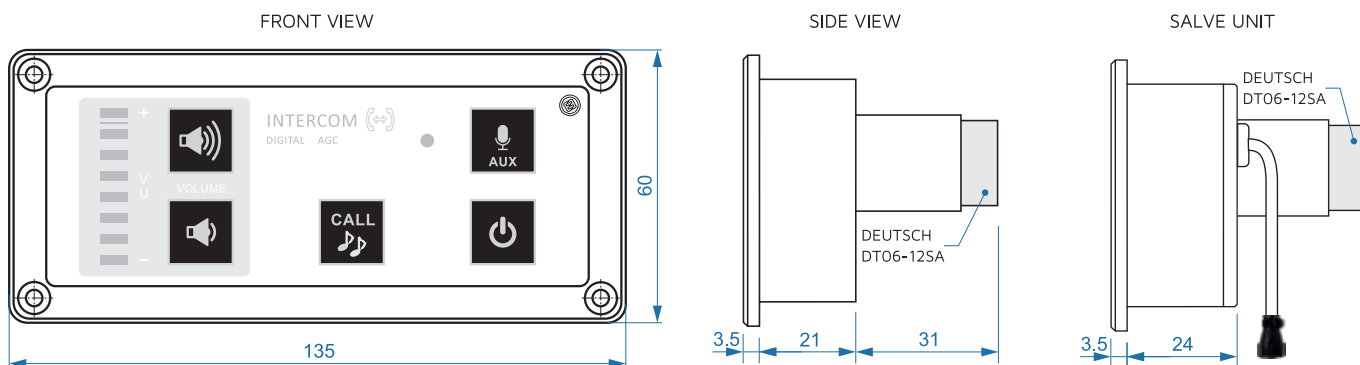

TOPOLOGY

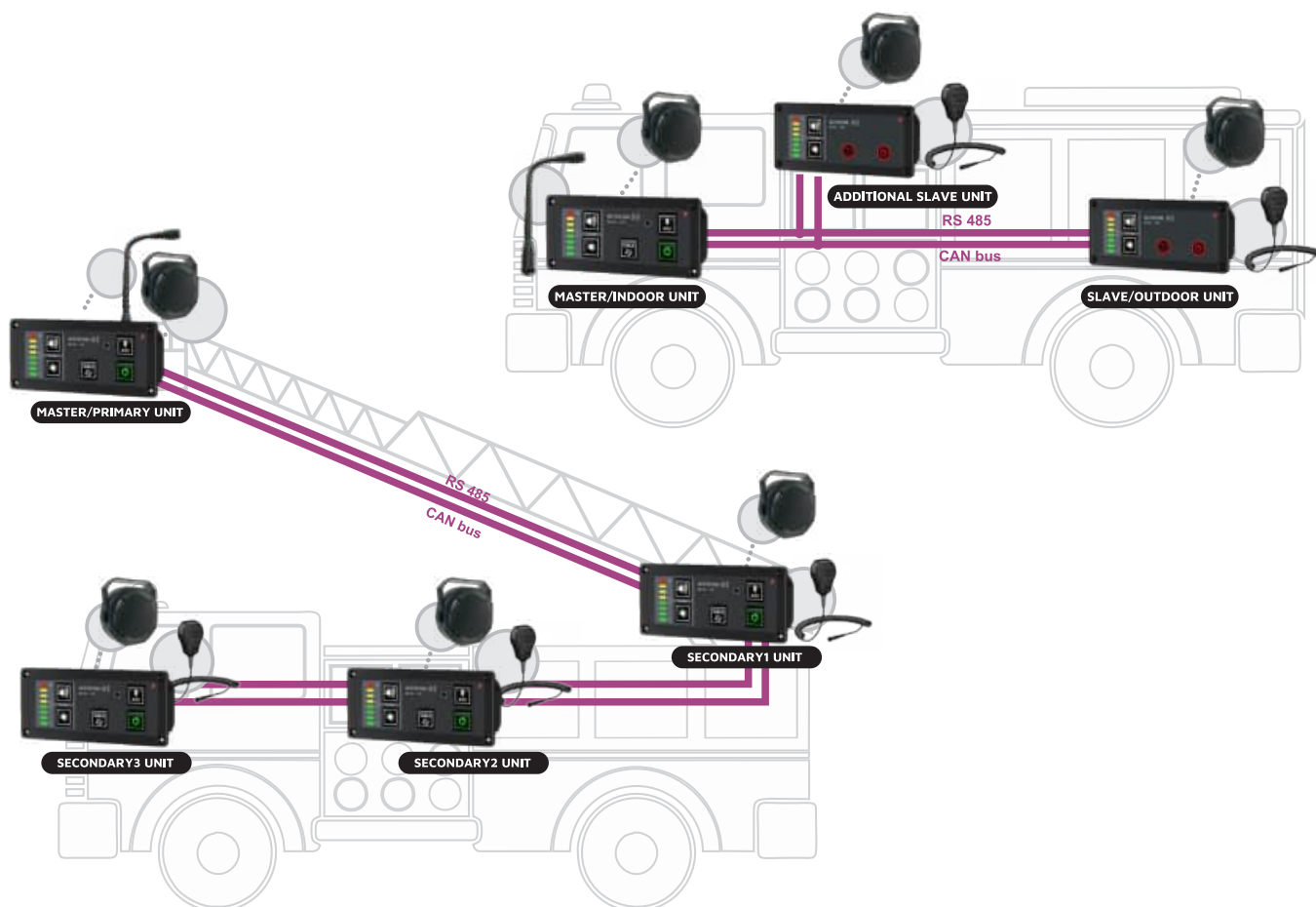

PRODUCT CODE

Intercom

Ordering code example:

I	N	T	S	1	O	-	2	4	H	M	C
INTERCOM UNIT TYPE MI: MASTER INDASH MO: MASTER OUTDASH S1: SLAVE 1 S2: SLAVE 2 S3: SLAVE 3			IP PROTECTION I: INDOOR O: OUTDOOR, SEALED			SUPPLY VOLTAGE 24: 20..32 V 12: 8..16 V			MIC. COFIGURATION HM: HANDHELD MIC./SPEAKER WITH PTT IM: INTEGRATED MIC. XM: XLR MIC. INPUT EM: EXTERNAL MIC. AND PTT		MISCELLAN. C: SLAVE CALL

PCU-PG



Icons shown on this keypad are for visual demonstration only.

Features and Benefits

- 1 **Pressure Governor with Cavitation Warning**
- 2 **Selection of Pressure by Large Rotary Knob (Encoder)**
- 3 **Integrated I/O Driver**
- 4 **CAN Bus Datalink**
- 5 **Alphanumeric Super-Bright LED Display**
- 6 **Integrated 10 Warning Lights**
- 7 **Programmable Keypad (2 Keys)**

The **PCU-PG** is an advanced electronic Pump Control Unit (PCU), designed with a variety of powerful features, including a pressure governor, manual keys for RPM adjustment (throttle increase and decrease), an idle button, two programmable keys, warning lights, and a super-bright alphanumeric LED display.

This versatile unit can also control other vehicle systems such as valves or display engine data. It also provides pump warning messages like cavitation and temperature alerts.

The unit can operate as a stand-alone device - integrated IOs, or it can be connected to the IO controller MMX EC1 to expand the IO functions.

The **PCU-PG** is an ideal solution for automated pressure control and vehicle system management, offering durability, flexibility, and reliability, even in challenging operational environments.



SPECIFICATIONS

POWER

Supply Voltage	8-32 V DC
Current	0.5 A maximum, no outputs active
Electrical Protection	overvoltage, transients, reverse polarity, load dump

INTERFACES

CAN	2x CAN, CAN Link
CAN termination	120 ohm, DIP switch
USB	1x USB 2.0, for firmware update

FEATURES

Pressure governor	automatic pressure regulation with cavitation warning
Display	alphanumeric super bright LED display, 11 digits
Warning lights	4 red, 4 amber, 2 green, total 10 LEDs
Keypad	2 soft keys (programmable) + 4 hard keys (pre-defined)
Signal Indicator	super bright green LED bar
Icons	freely selectable icons
Key Design	RIM-embossed keys with tactile feedback, operating force 8N, white backlit icons
Operating Life	>250.000 cycles
KEY dimension	23 x 23 mm
Rotary Knob	Encoder 16 pos. / 360° with push button
Day/Night operation	automatic - integrated light sensor

I/O

Sensor input	0.5-4.5 V
Sensor supply voltage	8-32V
Digital Input	configurable active low/high levels 0..Ub
IN1	with solder pad on PCB, freq. input (RPM sensor), protected
IN2	
Digital Output	positive switching (high-side), max. 2 A
OUT1 - OUT7	optional negative switching (low-side), max. 0.5 A
Loads	inductive, capacitive, resistive
Miscellaneous	Protection from short circuit and overload

ENVIRONMENT

IP Class (IEC529)	IP67 PCU, IP67 pressure sensor
EMC Conformity	EN61000-6-2 noise immunity EN61000-6-4 radiation of interference
Temperature Range	storage -40° to +85°C (-40° to 185°F) operating -40° to +85°C (-40° to 185°F)

ENCLOSURE

Housing Material	aluminium
Mounting	in-dash, with 4 screws M3 or 2.9 mm tapping screws
Matting Connector	Deutsch DT06-6S and DT06-12S

SIZE AND WEIGHT

W x H x D	173 x 123 x 54 mm, with mating connector
Weight	1 kg (2.20 lbs)



DIMENSIONS

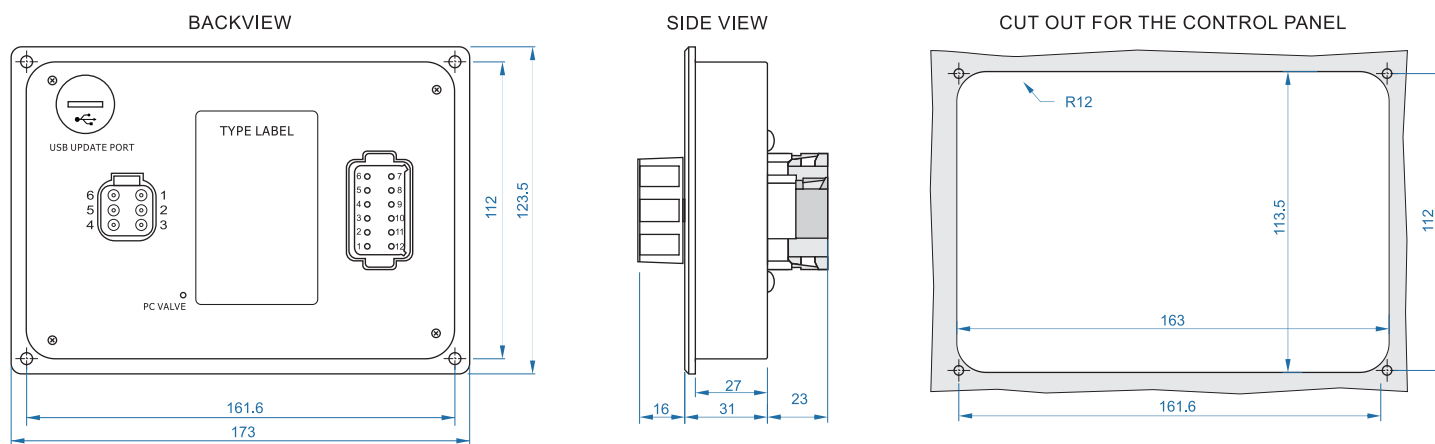

CONNECTIONS

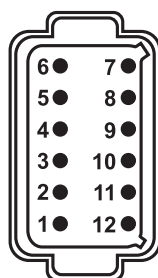

CONNECTION DEUTSCH DT06-6S

DESCRIPTION	PIN	PIN	DESCRIPTION
OUT 1 (INC +)	1	7	OUT 7 (KEY 2.2)
OUT 2 (DEC -)	2	8	INPUT +/- (P)
OUT 3 (IDLE)	3	9	INPUT +/- (PTO ON)
OUT 4 (KEY 1.1)	4	10	Sensor [V]/[mA] VCC+
OUT 5 (KEY 1.2)	5	11	Sensor [V] GND
OUT 6 (KEY 2.1)	6	12	SENSOR [V]/[MA] SIGNAL

CONNECTION DEUTSCH DT06-6S

DESCRIPTION	PIN	PIN	DESCRIPTION
BATTERY + (*15")	1	6	BATTERY -
CAN1 L	2	5	CAN1 H
(J1939) CAN2 L	3	4	CAN2 H (J1939)

PRODUCT CODE

Ordering code example:

P	C	U	-	P	G	-	2	0	P	-	S
PUMP CONTROL UNIT				PRESSURE GOVERNOR PG: PG FUNCTION			MAX. PRESSURE 20: 4 .. 20 BAR 40: 4 .. 40 BAR		OUTPUTS POLARITY P: POSITIVE VOLTAGE CONTROL SIGNALS N: NEGATIVE VOLTAGE CONTROL SIGNALS /: NO OUTPUTS, ONLY CAN		SENSOR OPTION S: PRESSURE SENSOR INCLUDED

PCU-WPG



Icons shown on this keypad are for visual demonstration only.

Features and Benefits

- 1 **Pressure Governor With Cavitation Warning**
- 2 **Alphanumeric Super Bright Led Display**
- 3 **Integrated Water Tank Level Gauge**
- 4 **Integrated Keypad - 12 Keys**
- 5 **Integrated 10 Warning Lights**
- 6 **Selection of Pressure by Rotary Knob - Encoder**
- 7 **Acoustic Signal - Integrated Buzzer**

The **PCU-WPG** is an electronic Pump Control Unit with an integrated pressure governor, water tank level gauge, keypad, warning lights and super bright alphanumeric LED display. It can also be used to control other vehicle systems such as valves, lighting, display engine data and water pump data, display pump warning messages as cavitation temperature, etc. The main function of PCU is Pressure Governor which allows automated regulation of the engine RPMs according to the pressure fluctuations in the pump. The automatic pressure regulation is turned ON by turning the rotation switch - encoder.

The integrated keypad is programmable. Each key can be configured to operate as a switch, push button or both as a special feature. Key label graphics are customizable and coloured according to function groups for easy recognition. Unused keys can be screened off with a dark label.



SPECIFICATIONS

POWER

Supply Voltage	8-32 V DC
Current	1 A maximum
Electrical Protection	overvoltage, transients, reverse polarity, load dump

INTERFACES

CAN	1 x CAN
CAN termination	120 ohm, DIP switch
USB	1x USB 2.0, for firmware update

FEATURES

Pressure governor	automatic pressure regulation with cavitation warning
Display	alphanumeric super bright LED display, 11 digit
Warning lights	4 red, 4 amber, 2 green, total 10 LEDs
Tank Level Gauge	1x, blue/red LED
Indicator increments	1/8
Keypad	8 soft keys (programmable) + 4 hard keys (pre-defined)
Signal Indicator	super bright green LED bar
Icons	freely selectable icons
Key Design	RIM-embossed keys with tactile feedback, operating force 8N, white backlit icons
Operating Life	>250.000 cycles
KEY dimension	23 x 23 mm
Rotary Knob	Encoder 16 pos. / 360° with push button
Day/Night operation	automatic - integrated light sensor
Acoustic Signal	Integrated Buzzer 100 dB

ENVIRONMENT

IP Class (IEC529)	IP67
EMC Conformity	EN61000-6-2 noise immunity EN61000-6-4 radiation of interference
Temperature Range	storage -40° to +85°C (-40° to 185°F) operating -40° to +85°C (-40° to 185°F)

ENCLOSURE

Housing Material	Aluminium
Mounting	in-dash with 4 screws M3 or 2.9 mm tapping screws
Matting Connector	Deutsch DT06-06S

SIZE AND WEIGHT

W x H x D	241 x 123 x 38, without matting connector
Weight	1 kg



DIMENSIONS

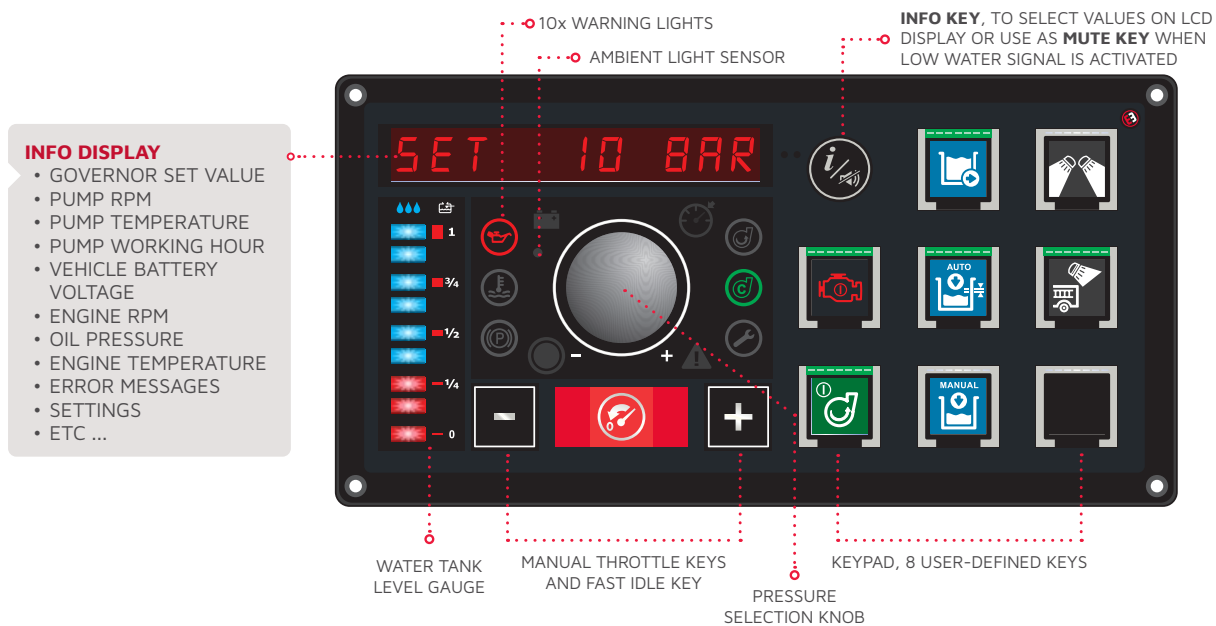
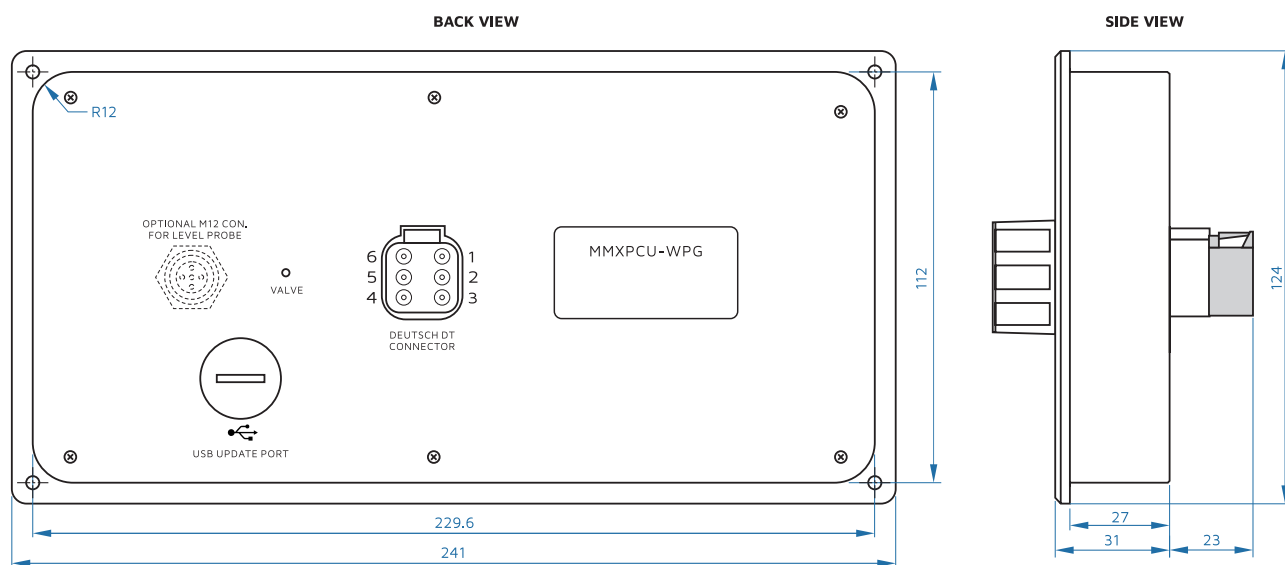

INFO DISPLAY

- GOVERNOR SET VALUE
- PUMP RPM
- PUMP TEMPERATURE
- PUMP WORKING HOUR
- VEHICLE BATTERY VOLTAGE
- ENGINE RPM
- OIL PRESSURE
- ENGINE TEMPERATURE
- ERROR MESSAGES
- SETTINGS
- ETC ...

CONNECTIONS

CONNECTION Deutsch DT06-6S

PIN DESCRIPTION

PIN	DESCRIPTION
1	BATTERY + ("15")
2	CAN L
3	CAN L, int. shorted to PIN 2
4	CAN H
5	CAN H, int. shorted to PIN 4
6	BATTERY -

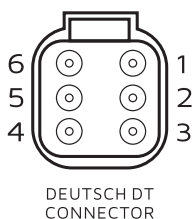

DEUTSCH DT CONNECTOR

PRODUCT CODE

PCU-WPG	Pump control unit with pressure governor, water tank level gauge, keypad, warning lights
PCU-W	Pump control unit with water tank level gauge, keypad, warning lights

For more options please contact the supplier.

PCU-WFPG



Icons shown on this keypad are for visual demonstration only.

Features and Benefits

- 1 **Pressure Governor With Cavitation Warning**
- 2 **Alphanumeric Super Bright Led Display**
- 3 **Integrated Water And Foam Tank Level Gauge**
- 4 **Integrated Keypad - 15 Keys**
- 5 **Integrated 10 Warning Lights**
- 6 **Selection of Pressure by Rotary Knob - Encoder**
- 7 **Acoustic Signal - Integrated Buzzert**

The **PCU-WFPG** is an electronic Pump Control Unit with an integrated pressure governor, water and foam tank level gauge, keypad, warning lights and super bright alphanumeric LED display. It can also be used to control other vehicle systems such as valves, lighting, display engine data and water pump data, display pump warning messages as cavitation temperature, etc. The main function of PCU is Pressure Governor which allows automated regulation of the engine RPMs according to the pressure fluctuations in the pump. The automatic pressure regulation is turned ON by turning the rotation switch - encoder.

The integrated keypad is programmable. Each key can be configured to operate as a switch, push button or both as a special feature. Key label graphics are customizable and coloured according to function groups for easy recognition. Unused keys can be screened off with a dark label.



SPECIFICATIONS

POWER

Supply Voltage	8-32 V DC
Current	1.2 A maximum
Electrical Protection	overvoltage, transients, reverse polarity, load dump

INTERFACES

CAN	1 x CAN
CAN termination	120 ohm, DIP switch
USB	1x USB 2.0, for firmware update

FEATURES

Pressure governor	automatic pressure regulation with cavitation warning
Display	alphanumeric super bright LED display, 11 digit
Warning lights	4 red, 4 amber, 2 green, total 10 LEDs
Tank Level Gauge	1x, blue/red LED, 1x yellow/red LEDs
Indicator increments	1/8
Keypad	11 soft keys (programmable) + 4 hard keys (pre-defined)
Signal Indicator	super bright green LED bar
Icons	freely selectable icons
Key Design	RIM-embossed keys with tactile feedback, operating force 8N, white backlit icons
Operating Life	>250.000 cycles
KEY dimension	23 x 23 mm
Rotary Knob	Encoder 16 pos. / 360° with push button
Day/Night operation	automatic - integrated light sensor
Acoustic Signal	Integrated Buzzer 100 dB

ENVIRONMENT

IP Class (IEC529)	IP67
EMC Conformity	EN61000-6-2 noise immunity EN61000-6-4 radiation of interference
Temperature Range	storage -40° to +85°C (-40° to 185°F) operating -40° to +85°C (-40° to 185°F)

ENCLOSURE

Housing Material	Aluminium
Mounting	in-dash with 4 screws M3 or 2.9 mm tapping screws
Matting Connector	Deutsch DT06-06S

SIZE AND WEIGHT

W x H x D	309 x 123 x 38, without matting connector
Weight	1.2 kg



DIMENSIONS

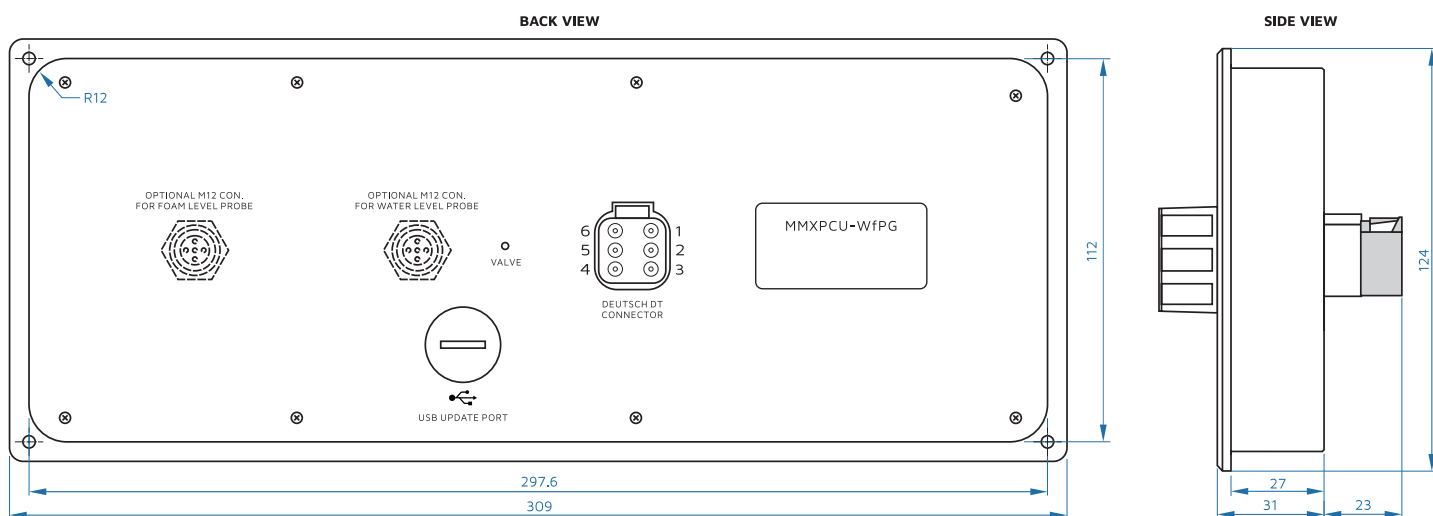

- INFO DISPLAY**
- GOVERNOR SET VALUE
 - PUMP RPM
 - PUMP TEMPERATURE
 - PUMP WORKING HOUR
 - VEHICLE BATTERY VOLTAGE
 - ENGINE RPM
 - OIL PRESSURE
 - ENGINE TEMPERATURE
 - ERROR MESSAGES
 - SETTINGS
 - ETC ...

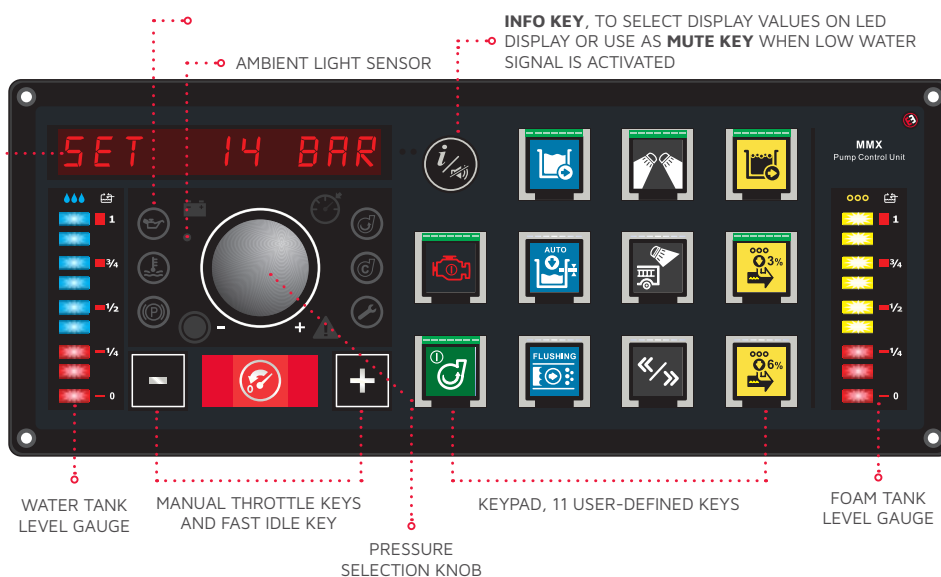

CONNECTIONS

CONNECTION Deutsch DT06-6S

PIN	DESCRIPTION
1	BATTERY + (*15")
2	CAN L
3	CAN L, int. shorted to PIN 2
4	CAN H
5	CAN H, int. shorted to PIN 4
6	BATTERY -

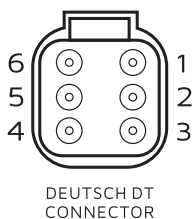

PRODUCT CODE

PCU-WFPG	Pump control unit with pressure governor, water tank level gauge, keypad, warning lights
PCU-WF	Pump control unit with water tank level gauge, keypad, warning lights
For more options please contact the supplier.	

PCU-WKPG



Icons shown on this keypad are for visual demonstration only.

Features and Benefits

- 1 **Pressure Governor With Cavitation Warning**
- 2 **Alphanumeric Super Bright Led Display**
- 3 **Integrated Water Tank Level Gauge**
- 4 **Integrated Keypad - 18 Keys**
- 5 **Integrated 10 Warning Lights**
- 6 **Selection of Pressure by Rotary Knob - Encoder**
- 7 **Acoustic Signal - Integrated Buzzer**

The **PCU-WKPG** is an electronic Pump Control Unit with an integrated pressure governor, water tank level gauge, keypad, warning lights and super bright alphanumeric LED display. It can also be used to control other vehicle systems such as valves, lighting, display engine data and water pump data, display pump warning messages as cavitation temperature, etc. The main function of PCU is Pressure Governor which allows automated regulation of the engine RPMs according to the pressure fluctuations in the pump. The automatic pressure regulation is turned ON by turning the rotation switch - encoder.

The integrated keypad is programmable. Each key can be configured to operate as a switch, push button or both as a special feature. Key label graphics are customizable and coloured according to function groups for easy recognition. Unused keys can be screened off with a dark label.



SPECIFICATIONS

POWER

Supply Voltage	8-32 V DC
Current	1.2 A maximum
Electrical Protection	overvoltage, transients, reverse polarity, load dump

INTERFACES

CAN	1 x CAN
CAN termination	120 ohm, DIP switch
USB	1x USB 2.0, for firmware update

FEATURES

Pressure governor	automatic pressure regulation with cavitation warning
Display	alphanumeric super bright LED display, 11 digit
Warning lights	4 red, 4 amber, 2 green, total 10 LEDs
Tank Level Gauge	1x, blue/red LED
Indicator increments	1/8
Keypad	14 soft keys (programmable) + 4 hard keys (pre-defined)
Signal Indicator	super bright green LED bar
Icons	freely selectable icons
Key Design	RIM-embossed keys with tactile feedback, operating force 8N, white backlit icons
Operating Life	>250.000 cycles
KEY dimension	23 x 23 mm
Rotary Knob	Encoder 16 pos. / 360° with push button
Day/Night operation	automatic - integrated light sensor
Acoustic Signal	Integrated Buzzer 100 dB

ENVIRONMENT

IP Class (IEC529)	IP67
EMC Conformity	EN61000-6-2 noise immunity EN61000-6-4 radiation of interference
Temperature Range	storage -40° to +85°C (-40° to 185°F) operating -40° to +85°C (-40° to 185°F)

ENCLOSURE

Housing Material	Aluminium
Mounting	in-dash with 4 screws M3 or 2.9 mm tapping screws
Matting Connector	Deutsch DT06-06S

SIZE AND WEIGHT

W x H x D	309 x 123 x 38, without matting connector
Weight	1.2 kg



DIMENSIONS

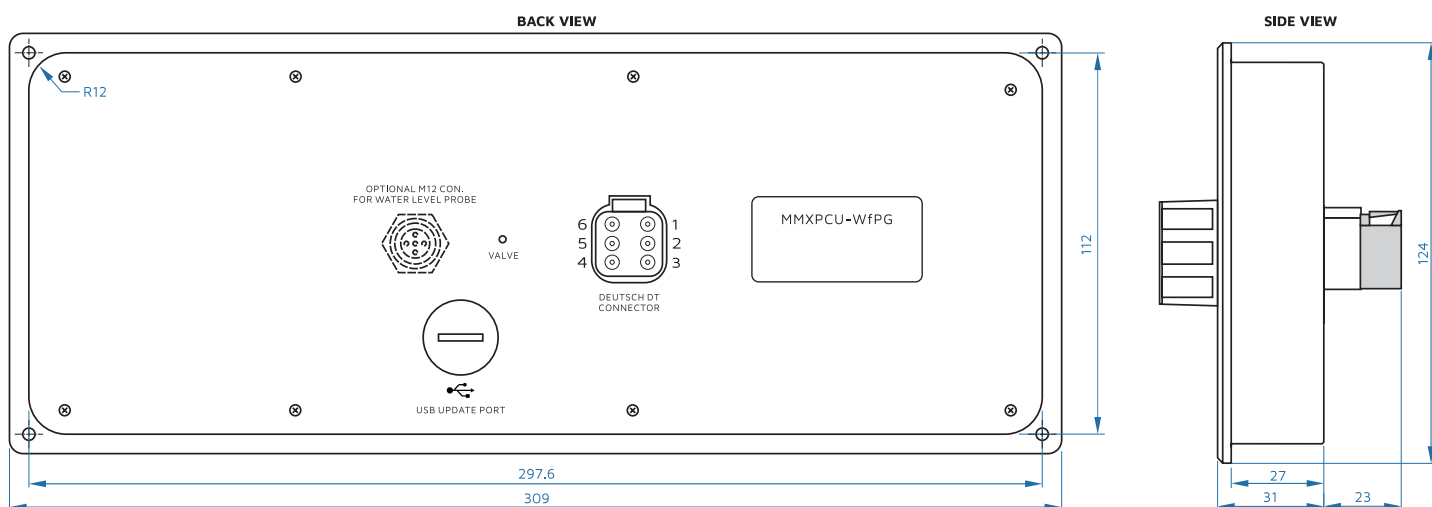

INFO DISPLAY

- GOVERNOR SET VALUE
- PUMP RPM
- PUMP TEMPERATURE
- PUMP WORKING HOUR
- VEHICLE BATTERY VOLTAGE
- ENGINE RPM
- OIL PRESSURE
- ENGINE TEMPERATURE
- ERROR MESSAGES
- SETTINGS
- ETC ...

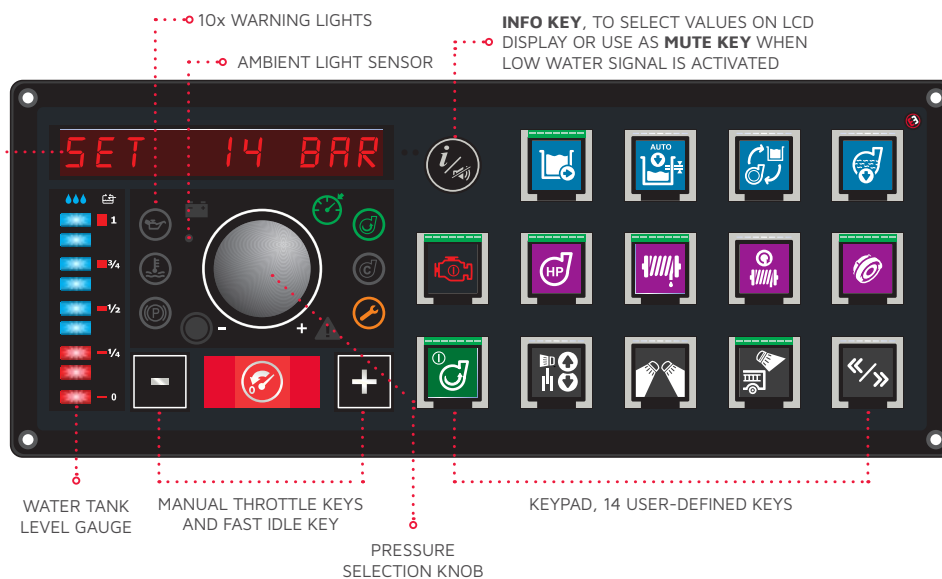

INFO KEY, TO SELECT VALUES ON LCD DISPLAY OR USE AS **MUTE KEY** WHEN LOW WATER SIGNAL IS ACTIVATED

CONNECTIONS

CONNECTION Deutsch DT06-6S

PIN DESCRIPTION

PIN	DESCRIPTION
1	BATTERY + (*15")
2	CAN L
3	CAN L, int. shorted to PIN 2
4	CAN H
5	CAN H, int. shorted to PIN 4
6	BATTERY -

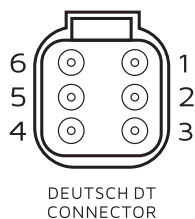

PRODUCT CODE

PCU-WKPG	Pump control unit with pressure governor, water tank level gauge, keypad, warning lights
PCU-WK	Pump control unit with water tank level gauge, keypad, warning lights
For more options please contact the supplier.	

KEYPAD MODULE

KPM-G21



Icons shown on this keypad are for visual demonstration only.

Features and Benefits

- 1 **White Backlit With Green Led Signal Indicator**
- 2 **Freely Selectable Icons**
- 3 **Can Bus Datalink**
- 4 **Super Bright Leds, Wide Viewing Angle**
- 5 **Integrated I/O Driver – Optional**
- 6 **Washable, Waterproof Alu. Housing**

Keypad module KPM-G21 uses two distinct keys, it is highly resistant to weather conditions and can survive extreme environments, what makes it perfect for installation outside or inside driver cabin. The keys are large, well-spaced and embossed, allowing a reliable pressure sensation with a tactile feedback even when wearing protective gloves. Each key has a large green LED signal indicator above the icon.

Type KPM-G210 has an integrated I/O controller with two low side power outputs and two inputs that can be useful if the keypad is used as a stand-alone device, not connected to the MMX system.

Keypad is programmable. Each key can be configured to operate as a switch or push button. Key label graphics are customizable, white backlit and coloured according to function groups for easy recognition. Unused keys can be screened off with a dark label.

Labels are inserted at the inner side of the front panel of the keypad. Several keypads located on different places can be connected over CAN BUS to collaborate. Keypad modules series KPM-G are a perfect solution in automotive, nautical, agriculture, utility vehicles and industrial sectors.

SPECIFICATIONS

POWER

Supply Voltage	8-32 V DC
Current	0.1 A maximum, no outputs active
Electrical Protection	overvoltage, transients, reverse polarity, load dump

INTERFACES

CAN	1 x CAN (only type without I/O driver)
CAN termination	120 ohm, DIP switch

ENVIRONMENT

IP Class (IEC529)	IP67, waterproof
EMC Conformity	EN61000-6-2 noise immunity EN61000-6-4 radiation of interference
Temperature Range	storage -40° to +85°C (-40° to 185°F) operating -40° to +85°C (-40° to 185°F)

KEYS

Key LED	white backlit
Signal Indicator	super bright green LED bar
Icons	freely selectable icons
Key Design	embossed keys with tactile feedback, operating force 8N
Operating Life	>250.000 cycles
KEY dimension	23.5 x 23.5 mm

ENCLOSURE

Housing Material	Aluminium
Mounting	in-dash, with 4 screws M3 or 3.5 mm (#8) tapping screws
Connector	Deutsch DTO6-06S

I/O - Only version with integrated IO driver

Digital Input	2 x active low level
Digital Output	2 x negative switching (low-side), max. 2 A
Loads	inductive, resistive
Miscellaneous	outputs not protected

SIZE AND WEIGHT

W x H x D	60 x 84 x 33 mm without connector
Weight	0.21 kg



DIMENSIONS

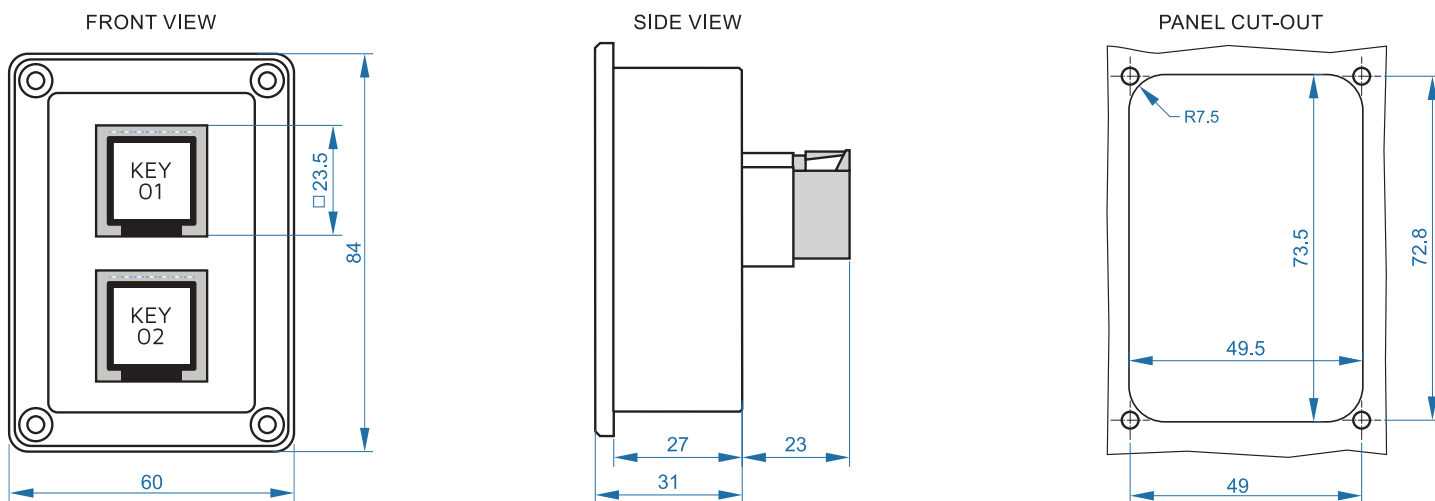

CONNECTIONS

CAN BUS MODULE

CONNECTION Deutsch DT06-6S

PIN DESCRIPTION

1	BATTERY + ("15")
2	CAN L
3	CAN L, int. shorted to PIN 2
4	CAN H
5	CAN H, int. shorted to PIN 4
6	BATTERY -

REAR VIEW (IP67)

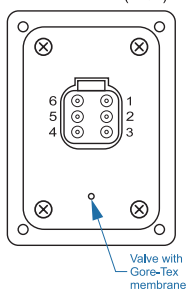

STAND-ALONE MODULE WITH I/O

CONNECTION Deutsch DT06-6S

PIN DESCRIPTION

1	BATTERY + ("15")
2	INPUT 1
3	OUTPUT 1
4	OUTPUT 2
5	INPUT 2
6	BATTERY -

PRODUCT CODE

KPM-G21	Keypad module, 2 keys (2 rows x 1 column), white backlit with green signal indicator, CAN BUS datalink
KPM-G210	Keypad module, 2 keys (2 rows x 1 column), white backlit with green signal indicator, integrated I/O driver, no CAN BUS datalink
For more options please contact the supplier.	

KEYPAD MODULE

KPM-G26 / KPM-GC26



SPECIFICATIONS

POWER

Supply Voltage	8-32 V DC
Current	0.5 A maximum, no outputs active
Electrical Protection	overvoltage, transients, reverse polarity, load dump

INTERFACES

CAN	1 x CAN (only type without I/O driver)
CAN termination	configurable termination 120 ohm via DIP switch
CAN Link	T-connection, node ID definition via software

ENVIRONMENT

IP Class	IP67, waterproof
EMC Conformity	EN61000-6-2 noise immunity EN61000-6-4 radiation of interference
Temperature Range	storage -40° to +85°C (-40° to 185°F) operating -40° to +85°C (-40° to 185°F)

KEYS

Key LED	first row RGB and white backlit, second row white backlit
Signal Indicator	Super bright green LED bar
Icons	freely selectable icons
Key Design	embossed keys with tactile feedback, operating force 8N
Operating Life	>250.000 cycles
KEY dimension	23.5 x 23.5 mm

ENCLOSURE

Housing Material	Aluminium
Mounting	in-dash, with 4 screws M4 or 3.5 mm (#8) tapping screws
Connectors	Deutsch DT06-06S

SIZE AND WEIGHT

W x H x D	241 x 84 x 33 mm without connector
Weight	0.70 kg

Icons shown on this keypad are for visual demonstration only.

Features and Benefits

- 1 White And RGB Backlit With Green LED Signal Indicator**
- 2 Used Also As Warning Lights (RGB LEDs Inside)**
- 3 Freely Selectable Icons**
- 4 CAN Bus Datalink**
- 5 Super Bright LEDs, Sunlight Readable**
- 6 Washable, Waterproof Alu. Housing**

Keypad module KPM-GC26 uses twelve distinct keys, it is highly resistant to weather conditions and can survive extreme environments, what makes it perfect for installation outside or inside driver cabin.

The keys are large, well-spaced and embossed, allowing a reliable pressure sensation with a tactile feedback even when wearing protective gloves. Each key has a large green LED signal indicator above the icon. Since the KEY backlit LED are white and RGB (colour) the keypad can be used as a combination of buttons and warning light indicators.

Keypad is programmable. Each key can be configured to operate as a switch or push button. Key label graphics are customizable, white backlit and coloured according to function groups for easy recognition. Unused keys can be screened off with a dark label. Labels are inserted at the inner side of the front panel of the keypad. Several keypads located on different places can be connected over CAN BUS to collaborate.

Keypad modules series KPM-GC are a perfect solution in automotive, nautical, agriculture, utility vehicles and industrial sectors.



DIMENSIONS

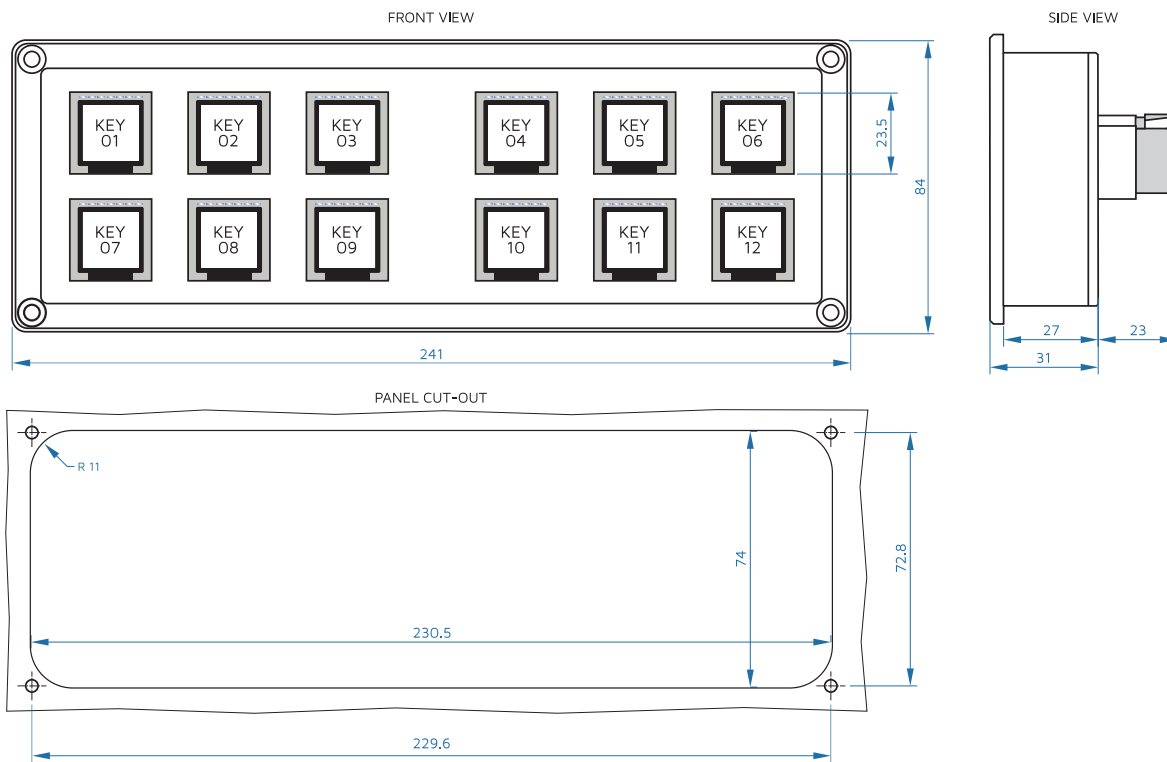

CONNECTIONS

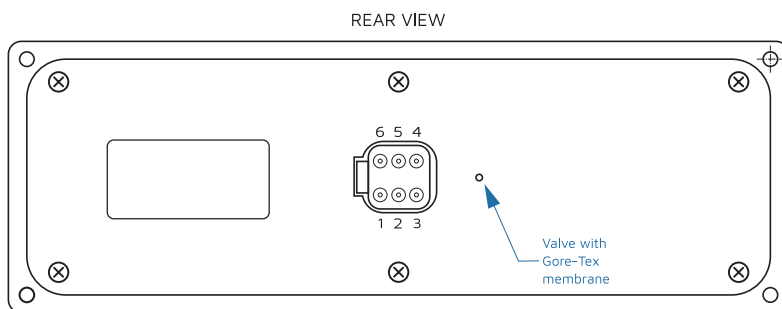

CONNECTION Deutsch DT06-6S

PIN DESCRIPTION

1	BATTERY + (~15V)
2	CAN L
3	CAN L - shorted to PIN 2
4	CAN H
5	CAN H - shorted to PIN 4
6	BATTERY -

PRODUCT CODE

KPM-G26 Keypad module, 12 keys (2 rows x 6 columns), white backlit with green signal indicator

KPM-GC26 Keypad module, 12 keys (2 rows x 6 columns), white and RGB backlit with green signal indicator

For more options please contact the supplier.

KEYPAD MODULE

KPM-G22J2



SPECIFICATIONS

POWER

Supply Voltage	8-32 V DC
Current	0.5 A maximum, no outputs active
Electrical Protection	overvoltage, transients, reverse polarity, load dump

INTERFACES

CAN	1 x CAN
CAN termination	configurable termination 120 ohm via DIP switch
CAN Link	T-connection, node ID definition via software

ENVIRONMENT

IP Class	IP67, waterproof
EMC Conformity	EN61000-6-2 noise immunity EN61000-6-4 radiation of interference
Temperature Range	storage -40° to +85°C (-40° to 185°F) operating -40° to +85°C (-40° to 185°F)

KEYS

Key LED	white backlit
Signal Indicator	Super bright green LED bar
Icons	freely selectable icons
Key Design	embossed keys with tactile feedback, operating force 8N
Operating Life	>250.000 cycles
KEY dimension	23.5 x 23.5 mm

JOYSTICS

Level Action	4-way with 4-way Limiter, spring centering
Operating Force	5 N +/- 1N
Max. Load	Vertical 200 N, Horizontal 150 N
Angle of Movement	+/- 15°
Operating Life	>300.000 cycles

ENCLOSURE

Housing Material	Aluminium, Joystick - Silicone
Mounting	in-dash, with 4 screws M4 or 3.5 mm (#8) tapping screws
Connectors	Deutsch DT06-06S

SIZE AND WEIGHT

W x H x D	241 x 84 x 33 mm without connector
Weight	0.75 kg

Icons shown on this keypad are for visual demonstration only.

Features and Benefits

- 1 Integrated 2 Joysticks - 4 Way with Limiter**
- 2 White Backlit Keys with Green LED Signal Indicator**
- 3 Freely Selectable Icons**
- 4 CAN Bus Datalink**
- 5 Super Bright LEDs, Sunlight Readable**
- 6 Washable, Waterproof Aluminium Housing**

Keypad module KPM-GC4J2 uses two 4-way Joysticks specifically engineered for demanding vehicle applications and 4 distinct keys. It is highly resistant to weather conditions and can survive extreme environments, what makes it perfect for installation outside or inside driver cabin. The keys are large, well-spaced and embossed, allowing a reliable pressure sensation with a tactile feedback even when wearing protective gloves. Each key has a large green LED signal indicator above the icon. Since the KEY backlit LED are white and RGB (colour) the keypad can be used as combination of buttons and warning light indicators.

Keypad is programmable. Each key can be configured to operate as a switch or a push button. Key label graphics are customizable, white backlit and coloured according to function groups for easy recognition. Unused keys can be screened off with a dark label. Labels are inserted at the inner side of the front panel of the keypad. Several keypads located on different places can be connected over CAN BUS to collaborate.

Keypad modules series KPM-GC42J are a perfect solution for agriculture and municipal vehicles as well as in industrial sectors.



DIMENSIONS

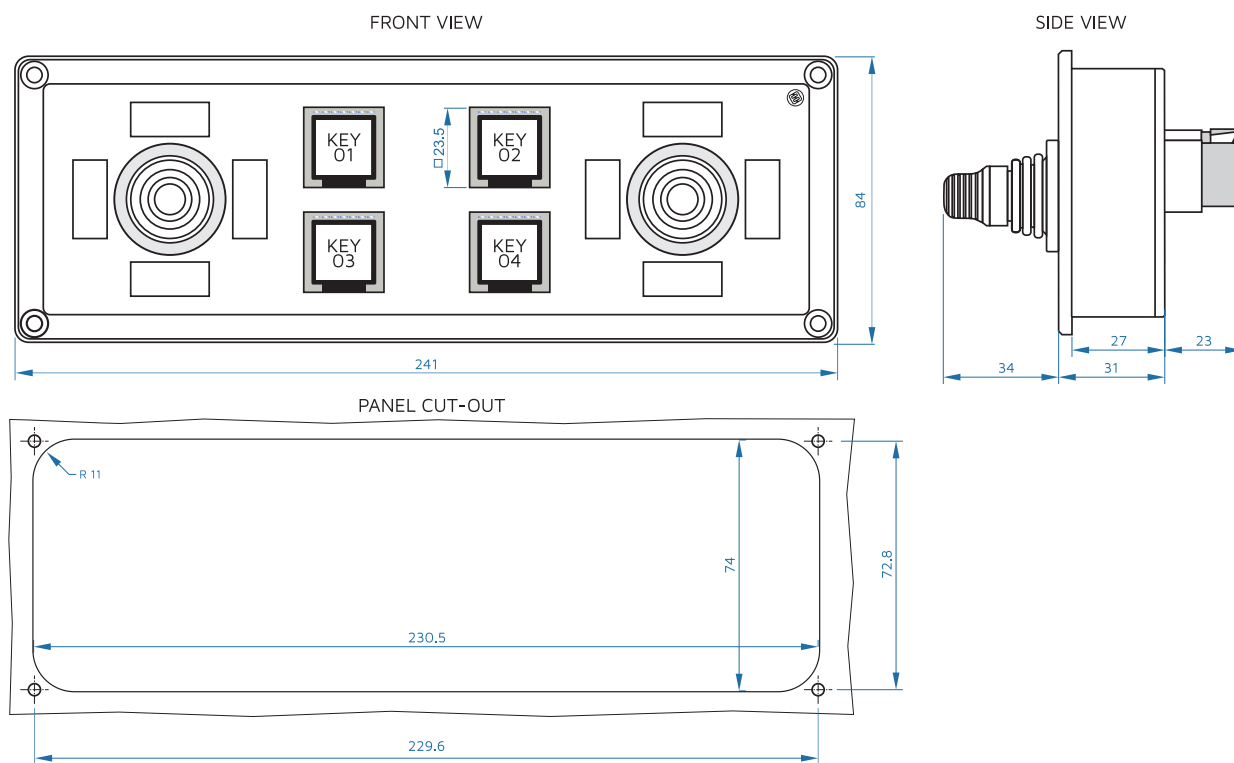

CONNECTIONS

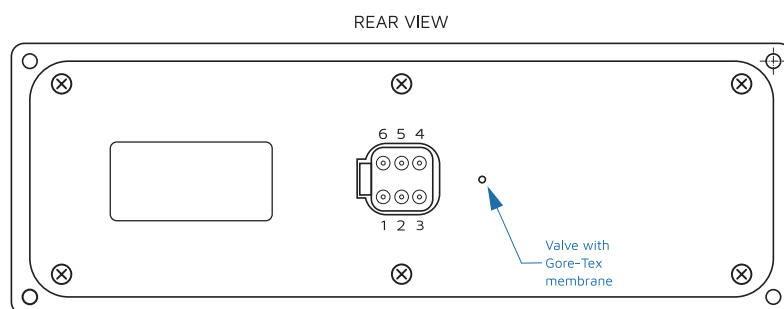

CONNECTION Deutsch DT06-6S

PIN DESCRIPTION

1	BATTERY + (~15V)
2	CAN L
3	CAN L - shorted to PIN 2
4	CAN H
5	CAN H - shorted to PIN 4
6	BATTERY -

PRODUCT CODE

KPM-G22J2 Keypad module, 2 Joysticks, 4 keys, white backlit with green signal indicator

For more options please contact the supplier.

KEYPAD MODULE

KPM-C22



Icons shown on this keypad are for visual demonstration only.

Features and Benefits

- 1 **RGB Backlit, Freely Selectable Icons**
- 2 **Light Sensor**
- 3 **Individually Adjustable Key Luminous Intensity**
- 4 **Low Installation Depth**
- 5 **"RIM" Embossing Keys**
- 6 **Washable, Waterproof Alu. Housing**

Keypad module KPM-C22 uses four distinct keys, it is highly resistant to weather conditions and can survive extreme environments, what makes it perfect for installation outside or inside driver cabin. The keys are large, well-spaced and "RIM" embossed, allowing a reliable pressure sensation with a tactile feedback even when wearing protective gloves. The keys can also be used in combination as warning lights.

Keypad is programmable. Each key can be configured to operate as a switch or push button. Corresponding key LED indicators are fully configurable, colour and luminance are adjustable. Key label graphics are customizable and backlit coloured according to function groups for easy recognition. Unused keys can be screened off with a dark label. Labels are inserted at the inner side of the front panel of the keypad. Several keypads located on different places can be connected over CAN BUS to collaborate. Keypad modules series KPM-C are a perfect solution in automotive, nautical, agriculture, utility vehicles and industrial sectors.



SPECIFICATIONS

POWER

Supply Voltage	8-32 V DC
Current	60 mA maximum
Electrical Protection	overvoltage, transients, reverse polarity, load dump

INTERFACES

CAN	1 x CAN (only type without I/O driver)
CAN termination	120 ohm, DIP switch

ENVIRONMENT

IP Class	with terminal block connection front panel - IP67, back - IP51
	with Deutsch DT06-6S connector complete IP67
EMC Conformity	EN61000-6-2 noise immunity EN61000-6-4 radiation of interference
Temperature Range	storage -40° to +85°C (-40° to 185°F) operating -40° to +85°C (-40° to 185°F)

KEYS

Key LED	RGB backlit icons
Icons	freely selectable icons
Brightness	individually adjustable key luminous intensity, dimmable - light sensor
Key Design	RIM-embossed keys with tactile feedback, operating force 8N
Operating Life	>250.000 cycles
KEY dimension	18 x 18 mm

ENCLOSURE

Housing Material	Aluminium
Mounting	in-dash with 4 screws M3 or 2.9 mm tapping screws
Connector	4 way Terminal Block or Automotive - Deutsch DT06-6

SIZE AND WEIGHT

W x H x D	69.7 x 59.8 x 19 without connector
Weight	0.12 kg (IP51), 0.14 kg (IP67)



DIMENSIONS

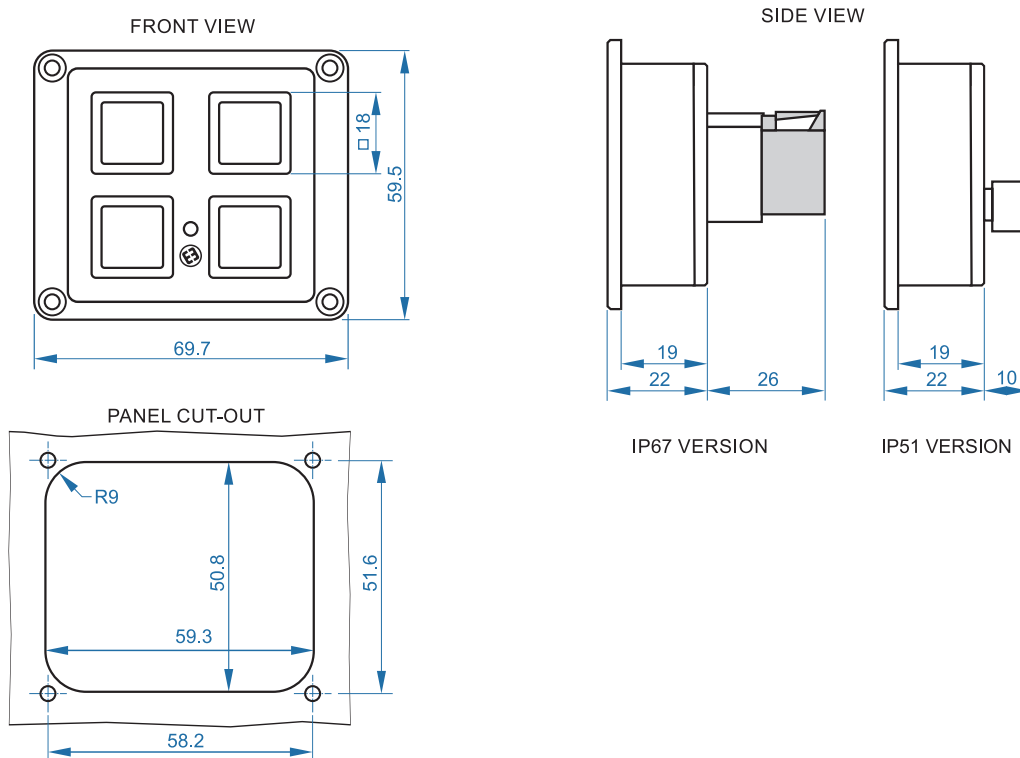

CONNECTIONS

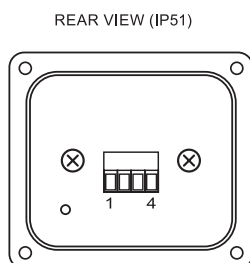

CONNECTION Terminal Block 4 way

PIN DESCRIPTION

1	CAN H
2	BATTERY -
3	BATTERY + ("15")
4	CAN L

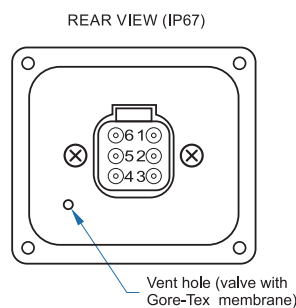

CONNECTION Deutsch DT06-6S

PIN DESCRIPTION

1	BATTERY + ("15")
2	CAN L
3	N/A
4	N/A
5	CAN H
6	BATTERY -

PRODUCT CODE

KPM-C22

Keypad module, 4 colour RGB backlit keys, (2 rows x 2 columns), IP51 connector

For more options please contact the supplier.

KEYPAD MODULE

KPM-C24



Icons shown on this keypad are for visual demonstration only.

Features and Benefits

- 1 **RGB Backlit, Freely Selectable Icons**
- 2 **Integrated I/O Driver - Optional**
- 3 **Light Sensor, Buzzer**
- 4 **Adjustable Key Luminous Intensity**
- 5 **Low Installation Depth**
- 6 **"RIM" Embossing Keys**
- 7 **Washable, Waterproof Alu. Housing**

Keypad module KPM-C24 uses eight distinct keys, it is highly resistant to weather conditions and can survive extreme environments, what makes it perfect for installation outside or inside driver cabin. The keys are large, well-spaced and "RIM" embossed, allowing a reliable pressure sensation with a tactile feedback even when wearing protective gloves. The keys can also be used in combination as warning lights.

Type KPM-C240 has an integrated I/O controller with high side power outputs and several inputs that can be useful if the keypad is used as a stand-alone device or as an extension of IO ports for controllers used in the MMX system.

Keypad is programmable. Each key can be configured to operate as a switch or push button. Corresponding key LED indicators are fully configurable, colour and luminance are adjustable. Key label graphics are customizable and backlit coloured according to function groups for easy recognition. Unused keys can be screened off with a dark label. Labels are inserted at the inner side of the front panel of the keypad. Several keypads located on different places can be connected over CAN BUS to collaborate. Keypad modules series KPM-C are a perfect solution in automotive, nautical, agriculture, utility vehicles and industrial sectors.



SPECIFICATIONS

POWER

Supply Voltage	8-32 V DC
Current	100 mA maximum
Electrical Protection	overvoltage, transients, reverse polarity, load dump

INTERFACES

CAN	1 x CAN (only type without I/O driver)
CAN termination	120 ohm, DIP switch

ENVIRONMENT

IP Class	with terminal block front panel - IP67, back - IP51 with Deutsch DT06 complete IP67
EMC Conformity	EN61000-6-2, EN61000-6-4
Temperature Range	storage -40° to +85°C (-40° to 185°F) operating -40° to +85°C (-40° to 185°F)

KEYS

Key LED	RGB backlit icons
Icons	freely selectable icons
Brightness	individually adjustable key luminous intensity, dimmable - light sensor
Key Design	RIM-embossed keys with tactile feedback, operating force 8N
Operating Life	>250.000 cycles
KEY dimension	18 x 18 mm

ENCLOSURE

Housing Material	Aluminium
Mounting	in-dash with 4 screws M3 or 2.9 mm tapping screws
Connectors	Power Supply/Can 4 way terminal block or Automotive - Deutsch DT06-6 I/O 14 way Terminal Block

I/O - Only version with integrated IO driver

Digital Inputs	1x configurable active low/high levels via software, 0..Ub, integrated pull-up/down resistor, protected 3 x positive - active high, 0..Ub, switch on level >4.6V, integrated pull-down resistor
Digital Outputs	8x positive switching (high-side), max. 1.5 A, total output from the unit may not exceed 8 A
Loads	inductive, capacitive, resistive
Miscellaneous	protection from short circuit and overload
SIZE AND WEIGHT	
W x H x D	121.8 x 59.8 x 19 without connector
Weight	0.18 kg (IP51), 0.22 kg (IP67)



DIMENSIONS

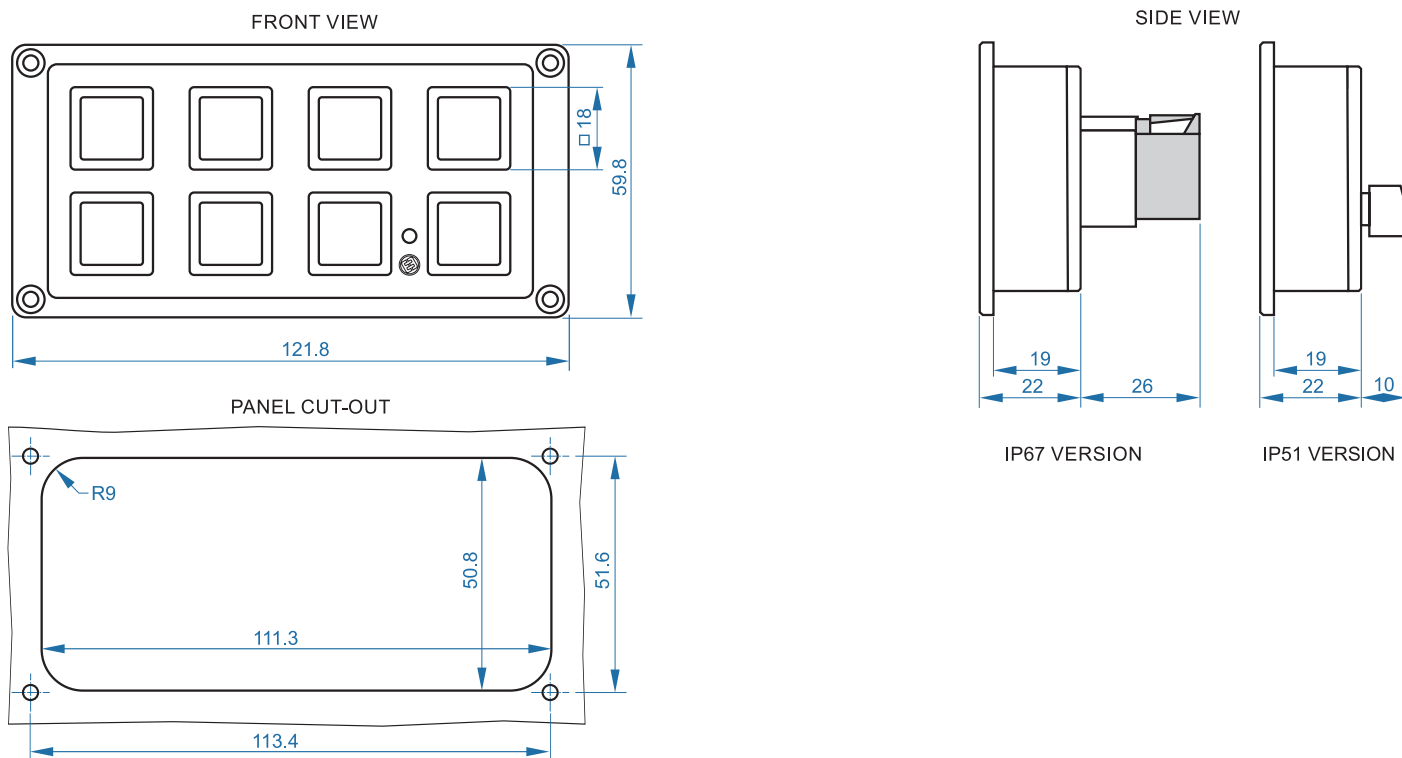

CONNECTIONS

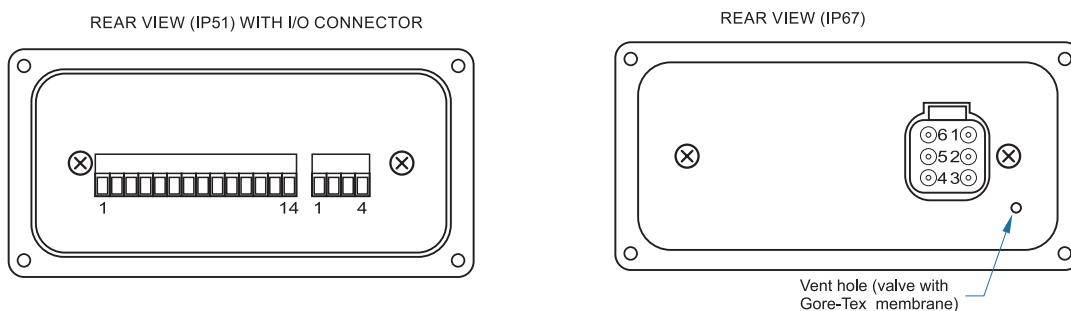

CONNECTION Terminal Block 14 way

PIN	DESCRIPTION
1-8	HIGH-SIDE OUTPUT
9	INPUT - CONFIGURABLE
10-12	INPUT - POSITIVE
13-14	N/A

CONNECTION Terminal Block 4 way

PIN	DESCRIPTION
1	CAN H
2	BATTERY -
3	BATTERY + ("15")
4	CAN L

CONNECTION Deutsch DT06-6S

PIN	DESCRIPTION
1	BATTERY + ("15")
2	CAN L
3	N/A
4	N/A
5	CAN H
6	BATTERY -

PRODUCT CODE

KPM-C24	Keypad module, 8 colour-RGB backlit keys, (2 rows x 4 columns), IP51 connector
KPM-C240	Keypad module, 8 colour-RGB backlit keys, (2 rows x 4 columns) with integrated IO driver, IP51 connector

For more options please contact the supplier.

KEYPAD MODULE

KPM-C26



Icons shown on this keypad are for visual demonstration only.

Features and Benefits

- 1 **RGB Backlit, Freely Selectable Icons**
- 2 **Integrated I/O Driver - Optional**
- 3 **Light Sensor, Buzzer**
- 4 **Adjustable Key Luminous Intensity**
- 5 **Low Installation Depth**
- 6 **"RIM" Embossing Keys**
- 7 **Washable, Waterproof Alu. Housing**

Keypad module KPM-C26 uses twelve distinct keys, it is highly resistant to weather conditions and can survive extreme environments, what makes it perfect for installation outside or inside driver cabin. The keys are large, well-spaced and "RIM" embossed, allowing a reliable pressure sensation with a tactile feedback even when wearing protective gloves. The keys can also be used in combination as warning lights.

Type KPM-C260 has an integrated I/O controller with high side power outputs and several inputs that can be useful if the keypad is used as a stand-alone device or as an extension of IO ports for controllers used in the MMX system.

Keypad is programmable. Each key can be configured to operate as a switch or push button. Corresponding key LED indicators are fully configurable, colour and luminance are adjustable. Key label graphics are customizable and backlit coloured according to function groups for easy recognition. Unused keys can be screened off with a dark label. Labels are inserted at the inner side of the front panel of the keypad. Several keypads located on different places can be connected over CAN BUS to collaborate. Keypad modules series KPM-C are a perfect solution in automotive, nautical, agriculture, utility vehicles and industrial sectors.



SPECIFICATIONS

POWER

Supply Voltage	8-32 V DC
Current	130 mA maximum
Electrical Protection	overvoltage, transients, reverse polarity, load dump

INTERFACES

CAN	1 x CAN (only type without I/O driver)
CAN termination	120 ohm, DIP switch

ENVIRONMENT

IP Class	with terminal block front panel - IP67, back - IP51 with Deutsch DT06 complete IP67
EMC Conformity	EN61000-6-2 noise immunity EN61000-6-4 radiation of interference
Temperature Range	storage -40° to +85°C (-40° to 185°F) operating -40° to +85°C (-40° to 185°F)

KEYS

Key LED	RGB backlit icons
Icons	freely selectable icons
Brightness	individually adjustable key luminous intensity, dimmable - light sensor
Key Design	RIM-embossed keys with tactile feedback, operating force 8N
Operating Life	>250.000 cycles
KEY dimension	18 x 18 mm

ENCLOSURE

Housing Material	Aluminium
Mounting	in-dash with 4 screws M3 or 2.9 mm tapping screws
Connectors	Power Supply/Can 4 way terminal block or Automotive - Deutsch DT06-6 I/O 14 way Terminal Block

I/O - Only version with integrated IO driver

Digital Inputs	6x configurable active low/high levels via software, 0 .. Ub, switch on level >4.6V, switch off level <2V, integrated pull-up/down resistor, protected
Digital Outputs	12 x positive switching (high-side), max. 1.5 A, total output from the unit may not exceed 8 A
Loads	inductive, capacitive, resistive
Miscellaneous	protection from short circuit and overload

SIZE AND WEIGHT

W x H x D	173.8 x 59.8 x 19 without connector
Weight	0.23 kg (IP51), 0.3 kg (IP67)



DIMENSIONS

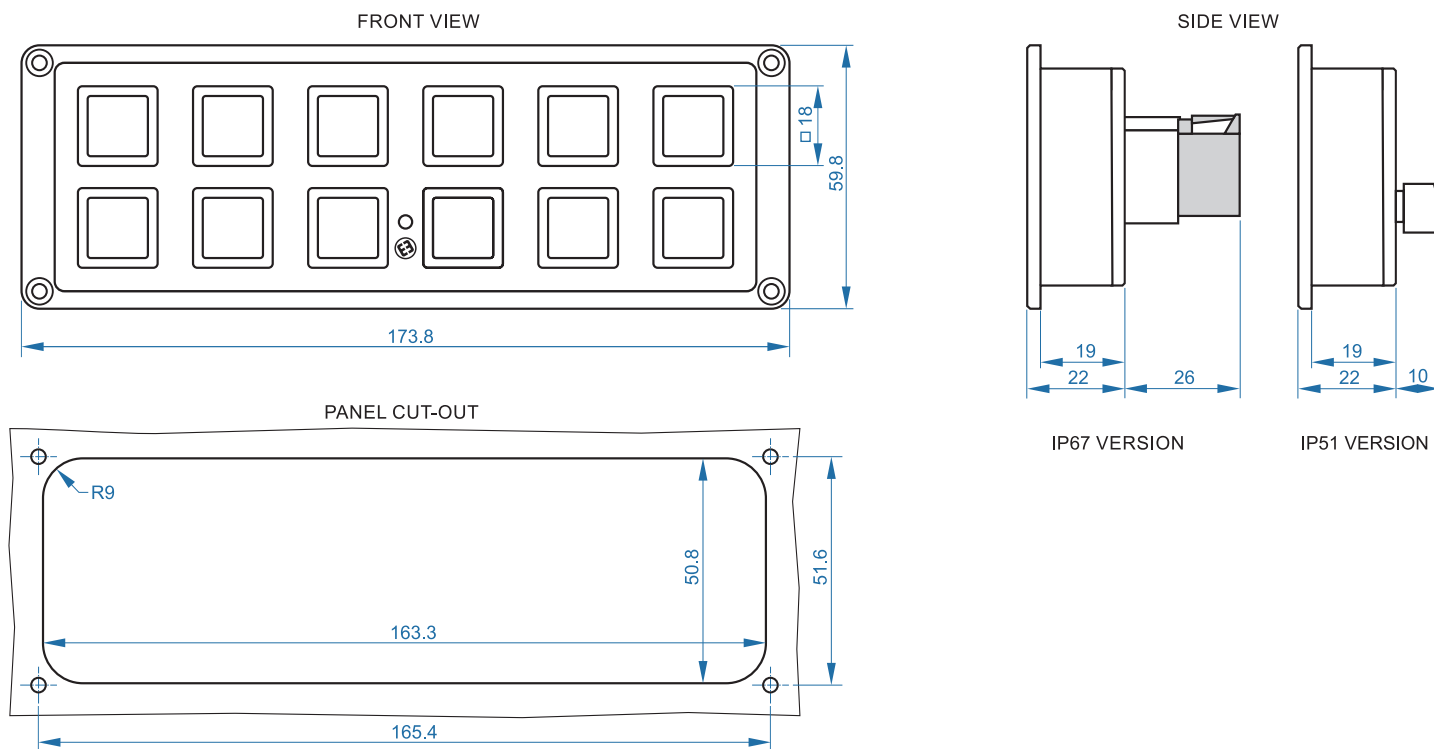

CONNECTIONS

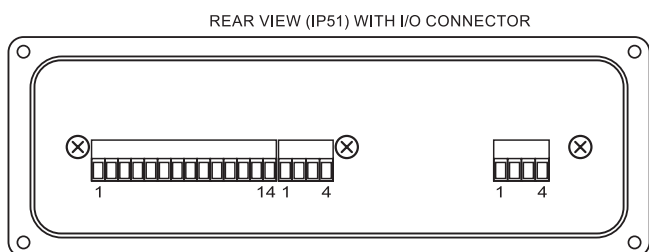

CONNECTION Terminal Block 14 way +4way

PIN	DESCRIPTION
1-12	HIGH-SIDE OUTPUT
13-14	INPUT - CONFIGURABLE
1-4	INPUT - POSITIVE

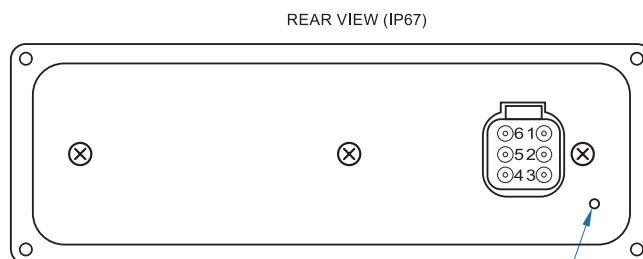

Vent hole (valve with Gore-Tex membrane)

CONNECTION Terminal Block 4 way

PIN	DESCRIPTION
1	CAN H
2	BATTERY -
3	BATTERY + ("15")
4	CAN L

CONNECTION Deutsch DT06-6S

PIN	DESCRIPTION
1	BATTERY + ("15")
2	CAN L
3	N/A
4	N/A
5	CAN H
6	BATTERY -

PRODUCT CODE

KPM-C26	Keypad module, 12 colour-RGB backlit keys, (2 rows x 6 columns), IP51 connector
KPM-C260	Keypad module, 12 colour RGB backlit keys, (2 rows x 6 columns) with integrated IO driver, IP51 connector

For more options please contact the supplier.

MMX LCD4K5



Optional Accessories



Features and Benefits

- 1 Sunlight Readable
- 2 Anti-Reflective Glass
- 3 5 Soft Keys
- 4 Video Input
- 5 Cabin Or Panel Mount

MMX LCD4 Display unit is very modern looking, cost-efficient, rugged 4.3" operator control panel for use on heavy-duty vehicles and work machines that must operate outdoor in harsh conditions. It is fully equipped with five soft-function keys, integrated buzzer, CAN bus and video inputs.

The display can be installed in-dash or out-dash with its specific articulated support.



SPECIFICATIONS

POWER

Supply Voltage	8-32 V DC
Current	500 mA maximum, no outputs active
Electrical Protection	overvoltage, transients, reverse polarity

INTERFACES

CAN	2 x CAN BUS ISO 11898, 2.0B high speed
Video	1 x PAL/NTSC
USB	1x USB 2.0, for firmware update

DISPLAY

Display type	Active matrix colour TFT LCD 4.3 inch, 16.2M colours, sunlight-readable, anti-reflective glass
Resolution	480 x 272 pixels, dot pitch 0.198,16:9
Viewing angle	80°
Luminance	800 cdm
Contrast ratio	600:1
Boot time	< 3 sec.

MISCELLANEOUS

Keys	5 soft keys, backlit
Touch	resistive - optional
Acoustic signal output	integrated buzzer max 85 dB
Inputs	2 Software configurable
Outputs	4 digital high side, 2 A max, optional
Operating system	Linux embedded
Kernel	ARM 32-bit uP, 2 MB Flash memory, 16 MB serial Flash

ENVIRONMENT

IP Class (IEC529)	IP65
EMC Conformity	EN61000-6-2 noise immunity EN61000-6-4 radiation of interference
Temperature Range	storage -40° to +85°C (-40° to 185°F) operating -40° to +85°C (-40° to 185°F)

ENCLOSURE

Housing Material	black rubber housing
Mounting	in-dash with springs or out-dash with articulated support
Matting Connector	Tyco-AMP Ampseal 1437288-6, 26 way

SIZE AND WEIGHT

W x H x D	134 x 91 x 33, without matting connector
Weight	250 g



DIMENSIONS

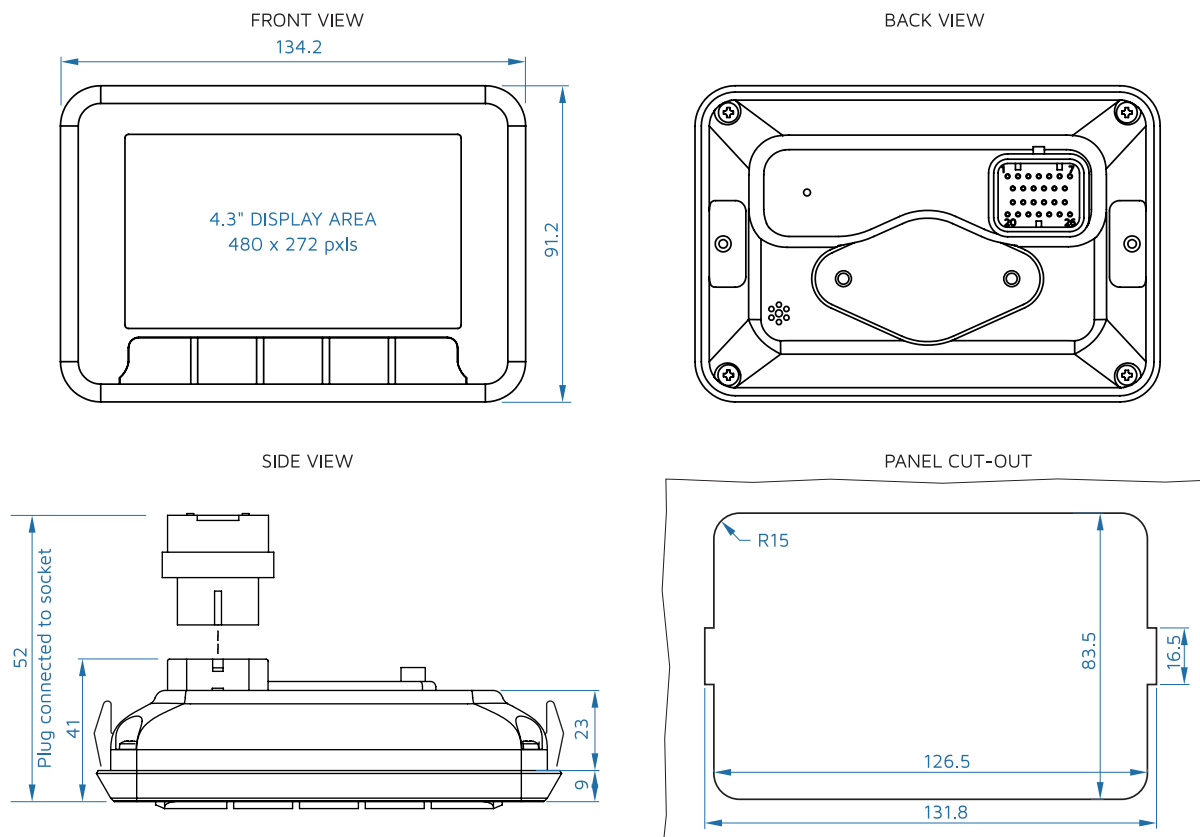

CONNECTIONS

PIN Description / wire colour

1	U BATT + (Ignition)
2	U BATT - „31“ (GND)
3	U BATT + „15“ (Ignition)
4	Shorted to PIN 3 - Camera Supply+ (Red)
5	CAN H line 1
6	CAN L line 1
7	Ground signal
8	CAN H line 2
9	CAN L line 2
10	Ground signal
11	Input 1
12	Input 2
13	Ground signal

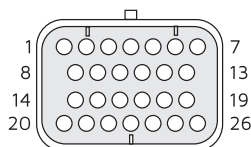

PIN Description / wire colour

14	Video Input (Yellow)
15	Video Camera GND (Black + Shield)
16	UART TX
17	UART RX
18	Ground signal
19	Output 1, optional
20	Output 2, optional
21	Output 3, optional
22	Output 4, optional
23	USB V Bus
24	USB Data - line
25	USB Data + line
26	USB Ground

PRODUCT CODE

MMXLCD4K5 4.3" LCD Control panel with 5 Keys, no touch

For more options please contact the supplier.

MMX LCD7

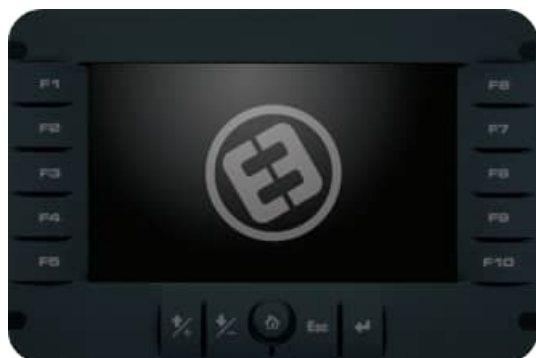

Optional Accessories



Features and Benefits

- 1 Sunlight Readable
- 2 Anti-Reflective Glass
- 3 10 Soft Keys
- 4 5 Pre-Defined Hard Keys
- 5 Video Input
- 6 Cabin Or Panel Mount

MMX LCD7 Display unit is cost-efficient, rugged operator control panel for use on heavy-duty vehicles and work machines that must operate outdoor in harsh conditions. It is fully equipped with five hard and ten soft-function keys, integrated buzzer, CAN bus and video inputs.

The display can be installed in-dash or out-dash with its specific articulated support.



SPECIFICATIONS

POWER

Supply Voltage	8-32 V DC
Current	1.2 A maximum
Electrical Protection	overvoltage, transients, reverse polarity, load dump

INTERFACES

CAN	2 x CAN BUS ISO 11898, 2.0B high speed
Video	1 x PAL/NTSC
USB	1x USB 2.0, for firmware update

DISPLAY

Display type	Active matrix colour TFT LCD 7 inch, 16.2M colours, sunlight-readable, anti-reflective glass
Resolution	800 x 480 pixels, dot pitch 0.1905 mm, 16:9
Viewing angle	Horizontal 130°, Vertical 110°
Luminance	500 cdm
Contrast ratio	600:1

MISCELLANEOUS

Keys	10 soft keys and 5 hard keys, backlit
Touch	resistive - optional
Acoustic signal output	integrated buzzer max 85 dB
Digital Output	Low side, 0.7 A max, optional
Operating system	Linux embedded
Kernel	ARM 32-bit uP, 256 MB Flash memory

ENVIRONMENT

IP Class (IEC529)	IP65
EMC Conformity	EN61000-6-2 noise immunity EN61000-6-4 radiation of interference
Temperature Range	storage -40° to +85°C (-40° to 185°F) operating -40° to +85°C (-40° to 185°F)

ENCLOSURE

Housing Material	grey rubber housing
Mounting	in-dash with 4 screws M3 or 2.9 mm tapping screws or out-dash with articulated support
Matting Connector	Tyco-AMP Ampseal 1437288-6, 26 way

SIZE AND WEIGHT

W x H x D	221 x 149 x 32, without matting connector
Weight	650 g



DIMENSIONS

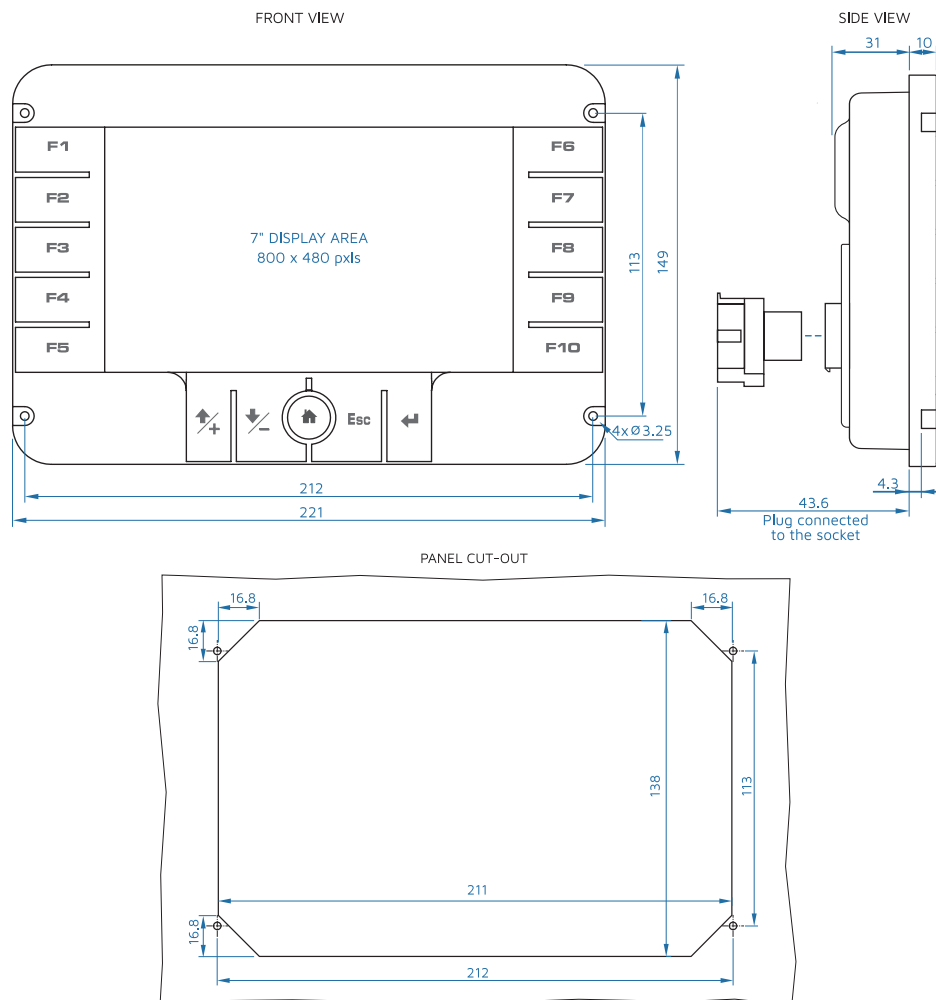

CONNECTIONS

PIN Description / wire colour

1	U BATT - „31“ (GND)
2	J1939 CAN L
3	J1939 CAN H
4	E-CAN1 L
5	E-CAN1 H
6	USB_D+ (Green)
7	USB_D+ (White)
8	-
9	-
10	-
11	-
12	USB_VCC (Red)
13	USB_GND (Grey)

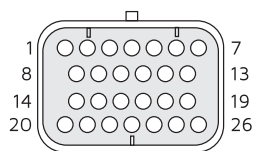

PIN Description / wire colour

14	-
15	-
16	-
17	Video Camera 2 GND (Black + Shield)
18	Video Input 2 (Yellow)
19	Video Input 1 (Yellow)
20	Video Camera 1 GND (Black + Shield)
21	Digital Output 1 (Optional)
22	Output - Shorted to PIN 21
23	U BATT + „15“, optional „30“
24	Shorted to PIN 23 - Camera Supply+ (Red)
25	U BATT + „15“ (Ignition)
26	Shorted to PIN 25 - Camera Supply+ (Red)

PRODUCT CODE

MMXLCD7 7" TFT LCD Control panel, antifog, no touch

For more options please contact the supplier.

MMX LCD10



Optional Accessories



Features and Benefits

- 1 **Wide Viewing Angle 170° (IPS)**
- 2 **Sunlight Readable, Anti-Reflective Glass**
- 3 **9 Soft Keys**
- 4 **Capacitive Multitouch Screen**
- 5 **Two Video Input, optional four**
- 6 **Cabin Or Panel Mount**
- 7 **Acoustic Signal-Integrated Buzzer**

MMX LCD10 is a high-end display solution, a rugged operator control panel for use on heavy-duty vehicles and work machines that must operate outdoor in harsh conditions. It is fully equipped with touch screen and nine soft-function keys, integrated buzzer, CAN bus and video inputs. It is a perfect solution for pump control outside the vehicle or for superstructure control from the cabin.

The display can be installed both in-dash or out-dash with its specific articulated support.

SPECIFICATIONS

POWER

Supply Voltage	8-32 V DC
Current	1.5 A maximum
Electrical Protection	overvoltage, transients, reverse polarity, load dump

INTERFACES

CAN	2 x CAN BUS ISO 11898, 2.0B high speed
Video	4 x PAL/NTSC simultaneous
USB	1x USB 2.0, for firmware update

DISPLAY

Display type	active matrix colour TFT LCD 10 inch, 16.2M colours, sunlight-readable, anti-reflective glass
Resolution	1280 x 800 pixels, dot pitch 0.1695 mm, 16:10
Viewing angle	horizontal 170°, Vertical 170° (IPS)
Luminance	850 cdm
Contrast ratio	800:01:00

MISCELLANEOUS

Keys	9 soft keys, backlit
Touch	integrated buzzer max 93 dB
Acoustic signal output	detect the intensity of the light in the environment
Digital Output	Low side, 0.7 A max, optional
Operating system	Linux embedded
Kernel	dual ARM Cortex A9, 32-bit uP, 8 GB Flash memory eMMC

ENVIRONMENT

IP Class (IEC529)	IP65
EMC Conformity	EN61000-6-2 noise immunity EN61000-6-4 radiation of interference
Temperature Range	storage -40° to +85°C (-40° to 185°F) operating -30° to +70°C (-40° to 185°F)

ENCLOSURE

Mounting	in-dash with 8 screws M3 or 2.9 mm tapping screws or out-dash with articulated support
Matting Connector	Tyco-AMP Ampseal 1437288-6, 26 way M12 8-way for two video cameras

SIZE AND WEIGHT

W x H x D	324 x 213 x 43, without matting connector
Weight	1500 g



DIMENSIONS

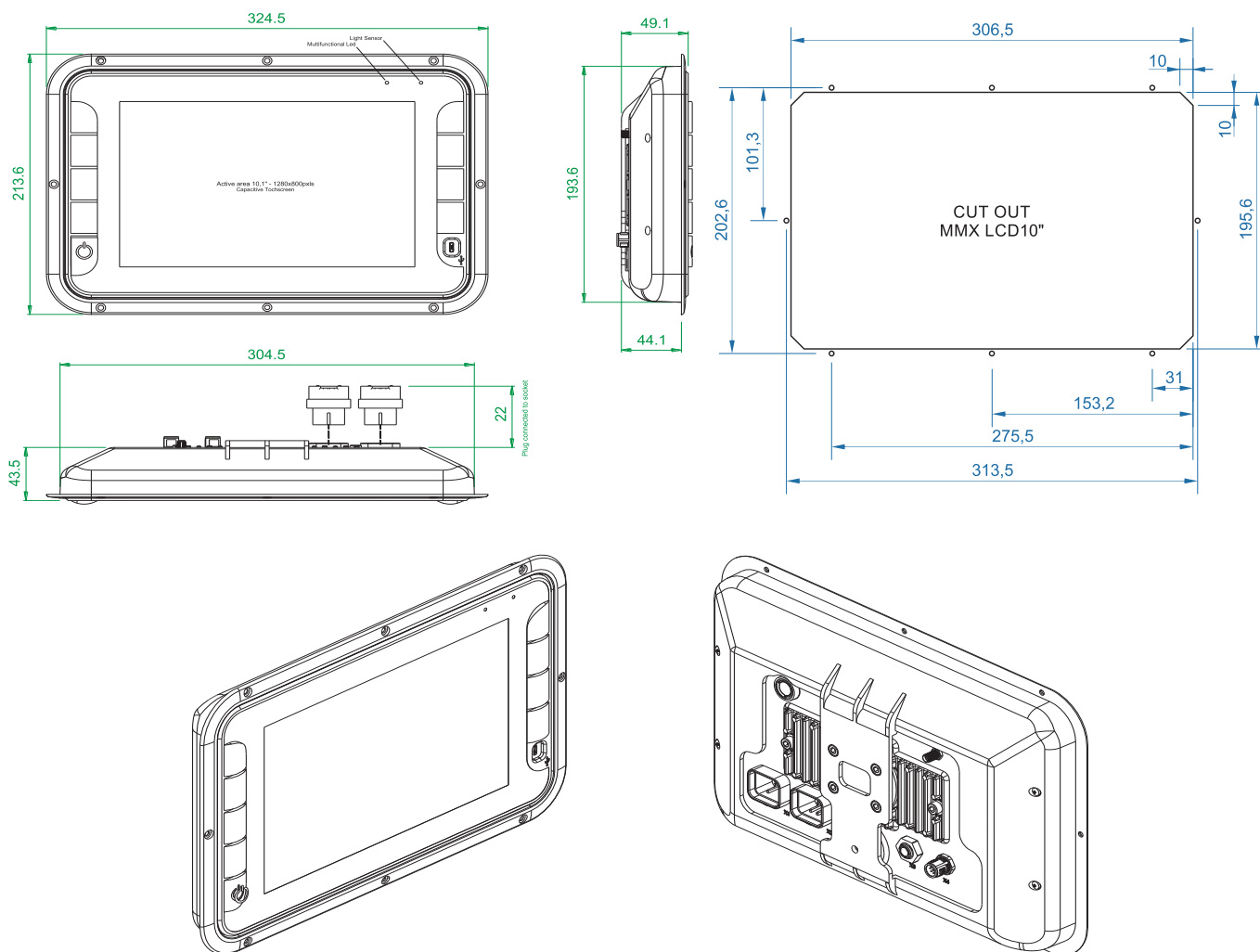

CONNECTIONS

Connector X1

PIN Description / wire colour

1	U BATT + (Ignition-15, optionally 30)
10	CAN1 H
11	CAN1 L
14	CAN2 H
20	CAN2 L
21	U batt - (GND-31)
22	U batt+ (Ignition -15)

CONNECTOR X1

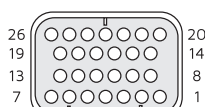

View from rear side
of the LCD

CONNECTOR M12-8way

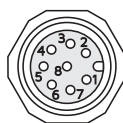

Connector M12 A-Coding male 8-way

PIN Description / wire colour

1	U batt +, positive power supply for external camera (Ignition "15")
2	U batt -, negative power supply for external camera (GND "31")
3	VIDEO IN1, PAL/NTSC video input
4	VIDEO GND, ground signal
5	U batt +, positive power supply for external camera (Ignition-15)
6	U batt -, negative power supply for external camera (GND-31)
7	VIDEO IN2, PAL/NTSC video input
8	VIDEO GND, ground signal

PRODUCT CODE

MMXLCD10 10" TFT LCD Control panel, 9 soft keys + touch

For more options please contact the supplier.

S&L MONITOR G2



Features and Benefits

- 1 **22 Digital Inputs, positive or negative**
- 2 **Photo sensor**
- 3 **Colour LEDs**
- 4 **Integrated Warning Buzzer - Optional**
- 5 **Integrated Remote Indicator for Water and Foam Tank Level**

The S&L Monitor is designed to monitor open side lockers (roller shutters), roof boxes, ladder and displays the status of different kinds of emergency and other lights on special vehicles.

Key advantage: Integrated Water and Foam remote level indicator as optional feature. State of monitored devices will be indicated with LED warning lights in different colours.

Integrated buzzer can signalize raised light mast, open roof boxes and open ladder to draw special attention to the driver at the moment that the parking brake has been released.

Monitoring is provided through 22 digital inputs. Digital inputs are connected via uP to altogether 37 LED lights. Digital inputs can be connected to GND or +UBatt signal, to detect the status of connected lamps, shutters or other equipment. An integrated photo sensor detects the ambient light and automatically adjusts the LED intensity for day or night operation.



SPECIFICATIONS

POWER

Supply Voltage	8-30 V DC
Current	0.2 A maximum, no outputs active
Electrical Protection	overvoltage, reverse polarity

INTERFACES

CAN	1 x CAN
CAN termination	configurable termination 120 ohm via DIP switch

ENVIRONMENT

IP Class (IEC529)	front panel - IP65
Temperature Range	storage -40° to +85°C (-40°F to 185°F) operating -40° to +85°C (-40°F to 185°F)

INPUTS

Digital Input	22 configurable-active low/high, levels 0 .. Ub
----------------------	---

ENCLOSURE

Housing Material	aluminium-black coated
Mounting	in-dash, with 4 screws M3 or 2.9 tapping screws
Connector	Terminal block 4 way, 8 way and 14 way connector, 0,5 to 1,5 mm ² (AWG 28-16)

MISCELLANEOUS

Level Indication	Water and Foam level optional, remote type
Indicator increments	1/4
Day/Night operation	automatic - integrated light sensor
LED indication	colour LED (white, blue, red, yellow)

SIZE AND WEIGHT

W x H x D [mm]	174 x 60 x 15 mm without connector
Weight	0.2 kg

How to order (use characters in **bold** to create order code)

Remote Indicator - Small

Ordering code example:

S	L	M	-	7	S	-	W	F
3S : 3 SHUTTERS (2+1) 5S : 5 SHUTTERS (2+2+1) 7S : 7 SHUTTERS (3+3+1) 9S : 10 SHUTTERS (4+4)			W : INTEGRATED WATER LEVEL INDICATOR		F : INTEGRATED FOAM LEVEL INDICATOR			

DIMENSIONS

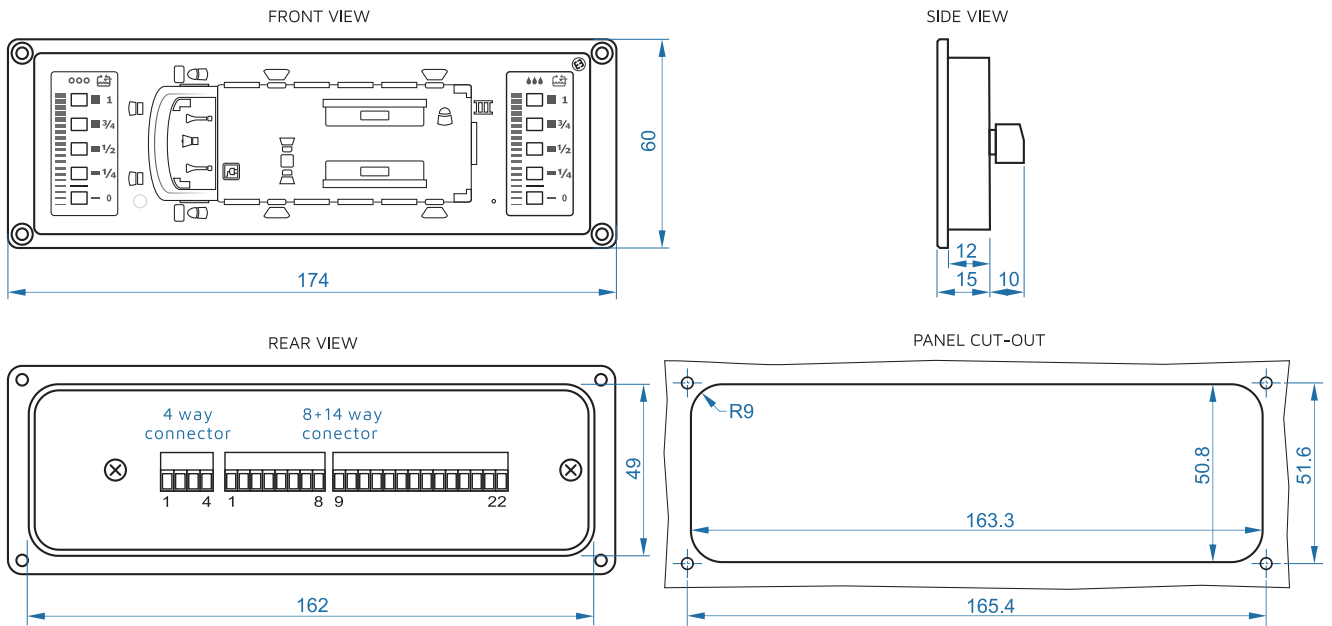

CONNECTIONS

CONNECTION Terminal Block 4 way

PIN DESCRIPTION

1	BATTERY + (~15V)
2	BATTERY -
3	CAN L
4	CAN H

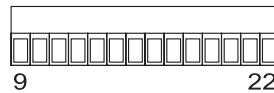
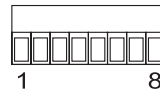

CONNECTION Terminal Block 8 way + 14 way

PIN DESCRIPTION

1-22 INPUT (configurable)

EXAMPLE OF DESIGN OPTIONS

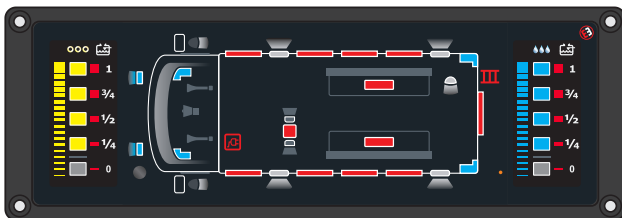

SLM-9S-WF

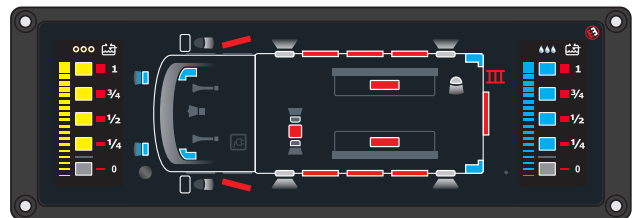

SLM-7S-WF

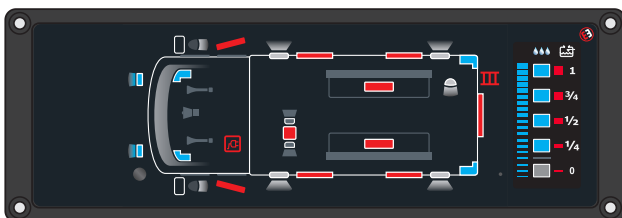

SLM-5S-W

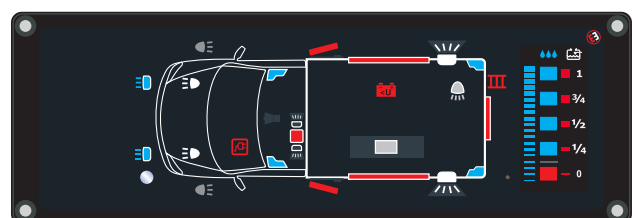

SLM-3S-W

TANK LEVEL GAUGE

INS-04/RIS-04/RTSS-04



Features and Benefits

- 1 180° Viewing Angle
- 2 I/O Driver For Low Water Warning, Autofill-Hysteresis, Mute input, Etc.
- 3 CAN Bus Interface
- 4 Super Bright LEDs
- 5 Dimmable-Light Sensor, Backlit
- 6 Low Installation Depth
- 7 Conductive Probe Input

INS-04 types of Tank Level Gauges are designed to display liquid's volume at an accuracy of 1/4 of the tank level using 5 ultra-bright LEDs. The gauge operates on basis of the conductance of the measured liquid using the conductive probe. The electrodes are placed at each quarter length of the probe.

Optional I/O driver can be integrated for low level warning output, autofill-hysteresis output, mute input, etc.

The Tank Level Gauge can be used as a stand-alone system or as a part of MMX system connected via CAN bus to IO Controller. Several slave indicators (small remote - RIS) can be connected to a master indicator INS to show the same value on different locations or in combination with a XL remote indicator (RIXL) for the vehicle sides.



SPECIFICATIONS

POWER

Supply Voltage	8-32 V DC
Current	0.5 A maximum, no outputs active
Electrical Protection	overvoltage, transients, reverse polarity

INTERFACES

CAN	1 x CAN
CAN termination	120 ohm

I/O

Probe input	Conductive probe with max. 5 rods
Digital Input	
IN1	configurable active low/high levels 0..Ub with solder pad on PCB, protected
IN2	active low level, config. input
Digital Output	
OUT1	<i>*Only version with integrated I/O driver</i> positive switching (high-side), max. 2 A (Low water warning)
OUT2	positive switching (high-side), max. 2 A (Autofill-Hysteresis)
OUT3-OUT4	positive switching (high-side), max. 2 A
OUT5	negative switching (low-side), max. 0.5 A
Loads	Inductive, capacitive, resistive

PROBE-OEM

Detection method	conductive
Probe length	250-2000 mm
Probe material	rods in stainless steel 316 (1.4305)

ENVIRONMENT

IP Class (IEC529)	front panel IP67, back IP20, probe IP67
EMC Conformity	EN61000-6-2 noise immunity EN61000-6-4 radiation of interference
Temperature Range	storage -40° to +85°C (-40° to 185°F) operating -40° to +85°C (-40° to 185°F)

ENCLOSURE

Housing Material	aluminium
Mounting	in-dash, with 4 screws M3 or 3.5 mm (#8) tapping screws
Connector	terminal block 4 or 14-way depending of options selected, probe connector M12

MISCELLANEOUS

Indicator increments	1/4
Day/Night operation	automatic - integrated light sensor
Front panel	backlit, colour coded for water and foam
Detectable substances	water, fire-smothering foam, gasoline, etc

SIZE AND WEIGHT

W x H x D	48 x 76 x 26 mm with connector
Weight	0.1 kg



DIMENSIONS

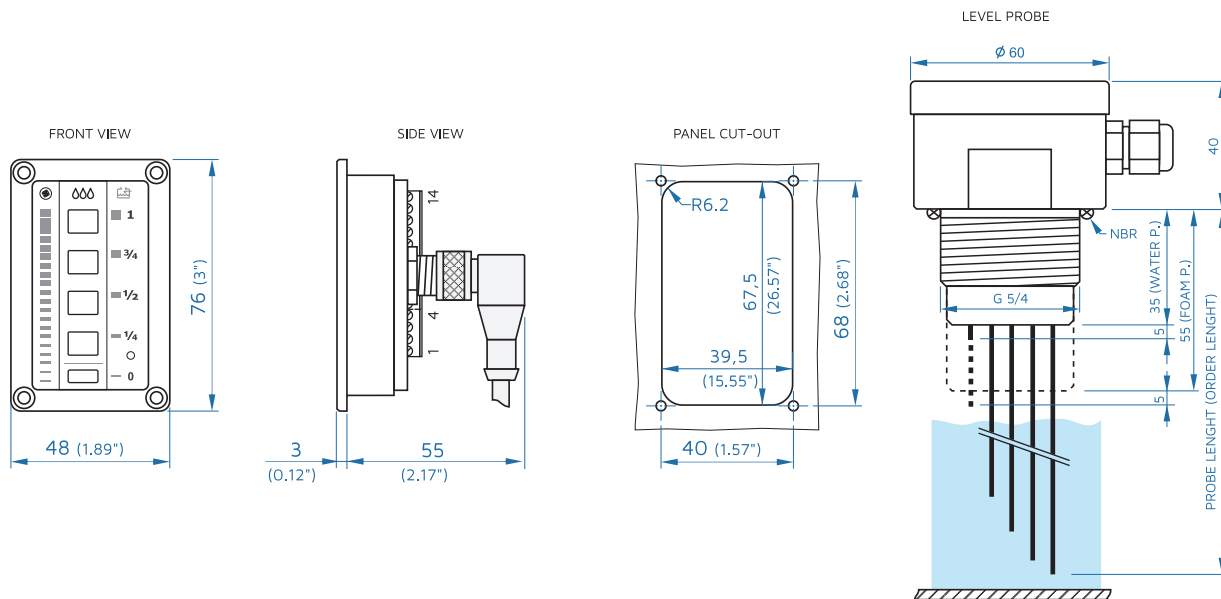

CONNECTIONS

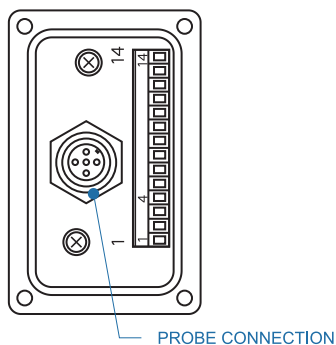

CONNECTION Terminal Block 4 or 14-way

PIN DESCRIPTION

1	BATTERY + (~15")
2	BATTERY - / GND
3	CAN L
4	CAN H
5	SENSOR [V]/[MA] VCC+
6	SENSOR [V]/[MA] SIGNAL
7	SENSOR [V] GND
8	DIGITAL IN1
9	OUT1 HIGH SIDE 2 A (LOW W/F)
10	OUT2 HIGH SIDE 2 A (HYST.)
11	OUT3 HIGH SIDE 2 A
12	OUT4 HIGH SIDE 2 A
13	OUT5 LOW SIDE 0.5 A
14	CONFIG/MUTE

PROBE CONNECTION

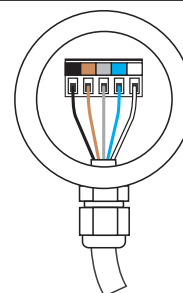

HOW TO ORDER (use characters in **bold** to create order code)

SET of master indicator small INS, conductive probe, sensor cabl

Ordering code example:

R	T	S	S	-	O	4	W	-	O	5	R	H	L	M
				O4 DISPLAY INCREM. 1/4	W: WATER F: FOAM	CABLE LENGTH, METERS (INCH) O5: 5 M (20") 10: 10 M (40") 15: 15 M (60")		R: LOW LEVEL WARNING	OUT1	OUT2	OUT3 - OUT6	INPUT IN1	M: MUTE OUT1	

Remote Indicator - Small

Ordering code example:

R	I	S	-	O	4	W	-	R	H		M
				O4 DISPLAY INCREM. 1/4	W: WATER F: FOAM	R: LOW LEVEL WARNING	OUT1	OUT2	OUT3 - OUT6	INPUT IN1	M: MUTE OUT1

***NOTE:** Selection of all three options R, H and L for the same indicator is standardly not possible. Options that are available are R, H, L and the combination RH

Master Indicator - Small

Ordering code example:

I	N	S	-	O	4	W	P	R	R	H	L	M
				O4 DISPLAY INCREM. 1/4	W: WATER F: FOAM	LEVEL PROBE INPUT PR: CONDUCTIVE PROBE	OUT1	OUT2	OUT3 - OUT6	INPUT IN1	M: MUTE OUT1	

TANK LEVEL GAUGE

INS-08/RIS-08/TLGS-08



Features and Benefits

- 1 180° Viewing Angle
- 2 I/O Driver For Low Water Warning, Autofill-Hysteresis, Mute Input, Etc.
- 3 CAN Bus Interface
- 4 Super Bright LEDs
- 5 Dimmable-Light Sensor, Backlit
- 6 Low Installation Depth
- 7 Multiple sensor input

INS-08 types of Tank Level Gauges are designed to display liquid's volume at an accuracy of 1/8 of the tank level using ultra-bright LEDs. The transducer measures the column of the liquid in the tank above the sensor process input and provides a signal that is proportional to the tank high. The unit standardly uses a pressure transducer with output 0.5-4.5 V. The sensor input is widely configurable and it can also be used for 0-10 V transducers, 4-20 mA transmitters or even resistive probe.

Optional I/O driver can be integrated for low level warning output, autofill-hysteresis output, mute input, etc.

The Tank Level Gauge can be used as a stand-alone system or as a part of MMX system connected via CAN bus to IO Controller. Several slave indicators (small remote - RIS) can be connected to a master indicator INS to show the same value on different locations or in combination with a XL remote indicator (RIXL) for the vehicle sides.



SPECIFICATIONS

POWER

Supply Voltage	8-32 V DC
Current	0.5 A maximum, no outputs active
Electrical Protection	overvoltage, transients, reverse polarity, load dump

INTERFACES

CAN	1 x CAN
CAN termination	120 ohm, DIP switch

I/O

Sensor input	0.5-4.5 V, 0-5V, 0-10V, 4-20 mA, resistive probe
Digital Input	
IN1	configurable active low/high levels 0..Ub with solder pad on PCB, protected active low level, config. input
IN2	
Digital Output	
OUT1	*Only version with integrated I/O driver positive switching (high-side), max. 2 A (Low water warning)
OUT2	positive switching (high-side), max. 2 A (Autofill-Hysteresis xx/xx%)
OUT3-OUT4	positive switching (high-side), max. 2 A
OUT5	negative switching (low-side), max. 0.5 A

Loads	inductive, capacitive, resistive
--------------	----------------------------------

ENVIRONMENT

IP Class (IEC529)	front panel IP67, back IP20
EMC Conformity	EN61000-6-2 noise immunity EN61000-6-4 radiation of interference
Temperature Range	storage -40° to +85°C (-40° to 185°F) operating -40° to +85°C (-40° to 185°F)

ENCLOSURE

Housing Material	aluminum
Mounting	in-dash, with 4 screws M3 or 3.5 mm (#8) tapping screws
Connector	terminal block 4 or 14-way depending of options selected

MISCELLANEOUS

Indicator increments	1/8 Standardly, 1/4 Optional
Day/Night operation	automatic - integrated light sensor
Front panel	backlit, colour coded for water and foam
Detectable substances	water, fire-smothering foam, gasoline, etc

SIZE AND WEIGHT

W x H x D	48 x 76 x 26 mm (1.9" x 3" x 1") with connector
Weight	0.10 kg (0.55 lbs)



DIMENSIONS

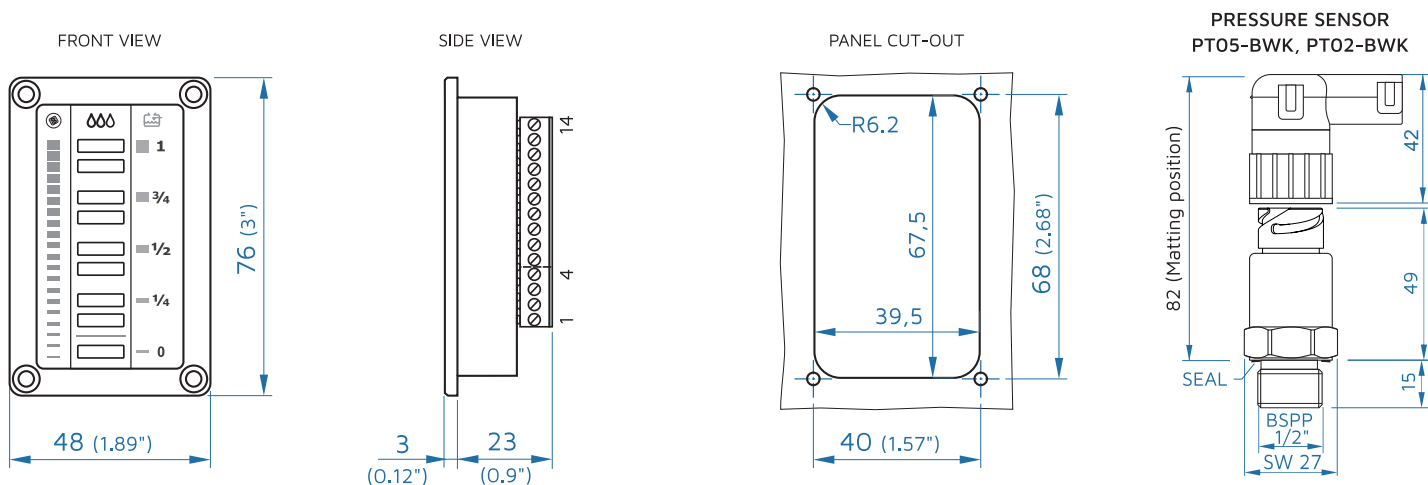

CONNECTIONS

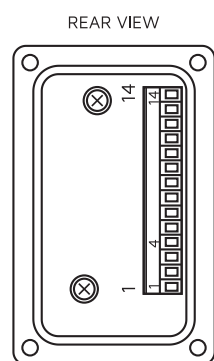

CONNECTION Terminal Block 4 or 14-way

PIN	DESCRIPTION
1	BATTERY + (*15")
2	BATTERY - / GND
3	CAN L
4	CAN H
5	SENSOR [V]/[MA] VCC+
6	SENSOR [V]/[MA] SIGNAL
7	SENSOR [V] GND
8	DIGITAL IN1
9	OUT1 HIGH SIDE 2 A (LOW W/F)
10	OUT2 HIGH SIDE 2 A (HYST.)
11	OUT3 HIGH SIDE 2 A
12	OUT4 HIGH SIDE 2 A
13	OUT5 LOW SIDE 0.5 A
14	CONFIG/MUTE

TRANSDUCER OEM

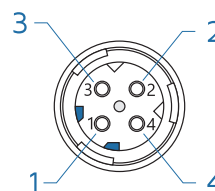

CONNECTION Twist Lock (ISO 15170)

PIN	VOLTAGE SENSOR	CURRENT SENSOR
1	BATTERY +	BATTERY +
2	GND	SIGNAL 4-20 MA
3	SIGNAL 0.5-4.5V	N/C
4	N/C	N/C

HOW TO ORDER (use characters in bold to create order code)

SET of master indicator small INS, sensor PT06-U4, sensor cable

Ordering code example:

T	L	G	S	-	O	8	W	-	O	5	R	H	L	M
08 DISPLAY INCREM.1/8 04 DISPLAY INCREM.1/4				W: WATER F: FOAM	CABLE LENGTH, METERS (INCH) 05: 5 M (20") 10: 10 M (40") 15: 15 M (60")			OUT1 R: LOW LEVEL WARNING	OUT2 H: AUTOFILL HYST. xx/xx % R: ADD. OUTPUT	OUT3 - OUT6 L: LLD5 DRIVER OUTPUTS	INPUT IN1 M: MUTE OUT1			

Remote Indicator - Small

Ordering code example:

R	I	S	-	O	8	W	-	R	H	L	M
08 DISPLAY INCREM.1/8 04 DISPLAY INCREM.1/4				W: WATER F: FOAM	OUT1 R: LOW LEVEL WARNING	OUT2 H: AUTOFILL HYST. xx/xx % R: ADD. OUTPUT	OUT3 - OUT6 L: LLD5 DRIVER OUTPUTS	INPUT IN1 M: MUTE OUT1			

***NOTE:** Selection of all three options R, H and L for the same indicator is standardly not possible. Options that are available are R, H, L and the combination RH

Master Indicator - Small

Ordering code example:

I	N	S	-	O	8	W	U	4	R	H	L	M
08 DISPLAY INCREM.1/8 04 DISPLAY INCREM.1/4				W: WATER F: FOAM	SENSOR INPUT / PROBE U4: 0,5-4,5V U1: 0-10 V I2: 4-20 MA	OUT1 R: LOW LEVEL WARNING	OUT2 H: AUTOFILL HYST. xx/xx % R: ADD. OUTPUT	OUT3 - OUT6 L: LLD5 DRIVER OUTPUTS	INPUT IN1 M: MUTE OUT1			

TANK LEVEL GAUGE

INL-08 / RIL-08 / TLGL-08



Features and Benefits

- 1 180° Viewing Angle
- 2 I/O Driver For Low Water Warning, Autofill-Hysteresis, Mute Input, Etc.
- 3 Can Bus Interface
- 4 Super Bright Leds
- 5 Dimmable-Light Sensor
- 6 Low Installation Depth
- 7 Washable, Waterproof Aluminium Housing

INL-08 types of Tank Level Gauges are designed to display liquid's volume at an accuracy of 1/8 of the tank level using ultra-bright LEDs. The transducer measures the column of the liquid in the tank above the sensor process input and provides a signal that is proportional to the tank high. The unit standardly uses a pressure transducer with output 0.5-4.5 V.

The sensor input is widely configurable and it can also be used for 0.5-4.5 V, 0-10 V, 4-20 mA sensors and conductive or resistive probes.

Optional I/O driver can be integrated for low level warning output, autofill-hysteresis output, mute input, etc.

The Tank Level Gauge can be used as a stand-alone system or as a part of MMX system connected via CAN bus to IO Controller. Several slave indicators (large remote - RIL) can be connected to a master indicator INL to show the same value on different locations or in combination with a small remote indicator (RIS) for the cabin and XL remote indicator (RIXL) for the vehicle sides.



SPECIFICATIONS

POWER

Supply Voltage	8-32 V DC
Current	0.5 A maximum, no outputs active
Electrical Protection	overvoltage, transients, reverse polarity, load dump

INTERFACES

CAN	1 x CAN
CAN termination	120 ohm, DIP switch

I/O

Sensor input	0.5-4.5 V, 0-5V, 0-10V, 4-20 mA, resistive probe, conductive probe through extra M12 connector
Digital Input	configurable active low/high levels 0..Ub, protected
Digital Output	<i>*Only version with integrated I/O driver</i>
OUT1	positive switching (high-side), max. 3 A (Low water warning)
OUT2	positive switching (high-side), max. 1.5 A (Autofill-Hysteresis xx/xx%)
OUT3	positive switching (high-side), max. 1.5 A
OUT4	negative switching (low-side), max. 0.5 A

Loads	inductive, capacitive, resistive
Miscellaneous	protection from short circuit and overload

ENVIRONMENT

IP Class (IEC529)	IP67, waterproof
EMC Conformity	EN61000-6-2 noise immunity EN61000-6-4 radiation of interference
Temperature Range	storage -40° to +85°C (-40° to 185°F) operating -40° to +85°C (-40° to 185°F)

ENCLOSURE

Housing Material	Aluminium
Mounting	in-dash, with 4 screws M3 or 3.5 mm (#8) tapping screws
Matting Connector	Deutsch DT06-12S

MISCELLANEOUS

Indicator increments	1/8
Day/Night operation	automatic - integrated light sensor
Front panel	backlit, colour coded for water and foam
Detectable substances	water, fire-smothering foam, gasoline, etc

SIZE AND WEIGHT

W x H x D	66 x 112 x 23 mm (2.6"x4.41"x0.9") without connector
Weight	0.25 kg (0.55 lbs)



DIMENSIONS

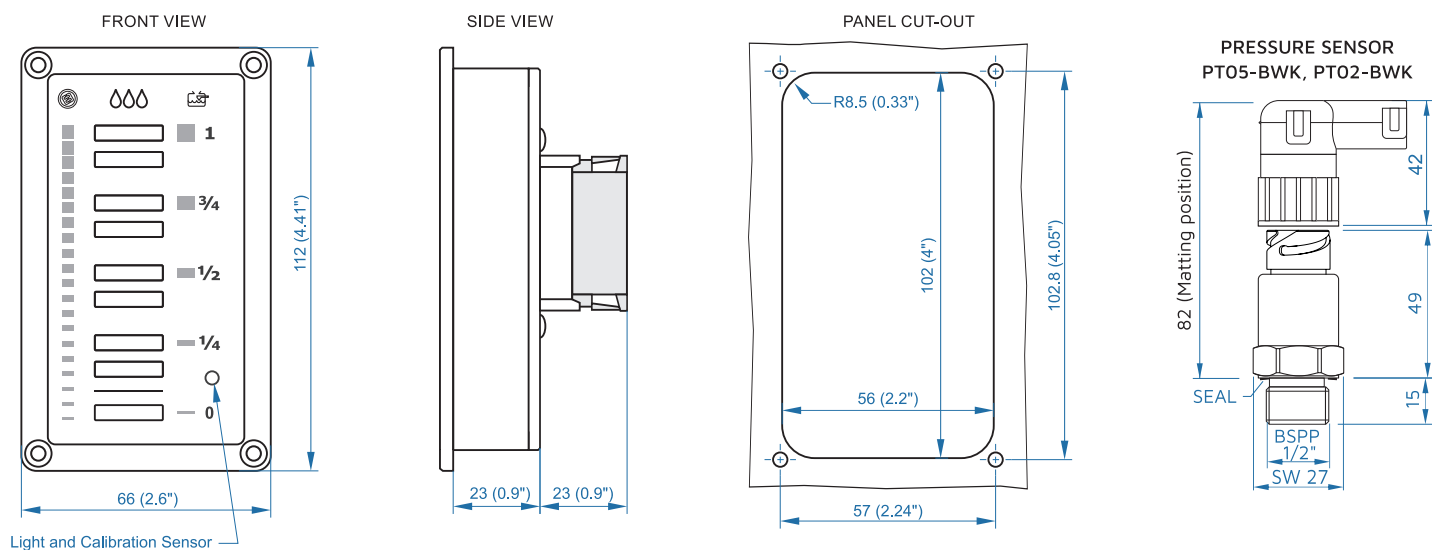

CONNECTIONS

TRANSDUCER OEM

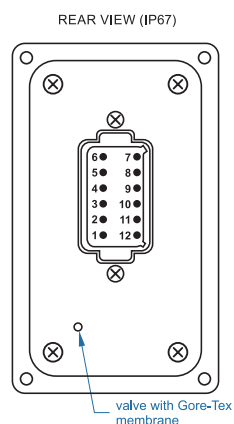

CONNECTION Deutsch DT06-6S

PIN DESCRIPTION

1	BATTERY + (*15")
2	CAN L
3	CAN H
4	SENSOR [V] OR [mA] VCC+
5	SENSOR [V] GND
6	SENSOR [V] OR [mA] SIGNAL
7	OUT1 (OPTIONAL), e.g. LOW WATER
8	OUT2 (OPTIONAL), e.g. AUTOFILL
9	OUT3 (OPTIONAL)
10	OUT4 (OPTIONAL)
11	INPUT (OPTIONAL)
12	BATTERY -

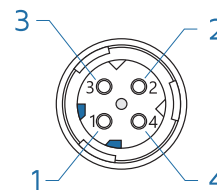

CONNECTION Twist Lock (ISO 15170)

PIN	VOLTAGE SENSOR	CURRENT SENSOR
1	BATTERY +	BATTERY +
2	GND	SIGNAL 4-20 MA
3	SIGNAL 0.5-4.5V	N/C
4	N/C	N/C

HOW TO ORDER (use characters in **bold** to create order code)

SET of Master Indicator - Large INL, Sensor PT06-U4, Sensor cable

Ordering code example:

T	L	G	L	-	O	8	W	-	O	5	R	H		
					08 DISPLAY INCREM. 1/8		W: WATER F: FOAM		CABLE LENGTH, METERS (INCH) 05: 5 M (20") 10: 10 M (40") 15: 15 M (60")		R: LOW LEVEL WARNING	H: AUTOFILL HYST. xx/xx % R: ADD. OUTPUT	O: 1X 1.5A POSITIVE 1X 0.5A NEGATIVE	M: MUTE OUT1

Remote Indicator - Large

Ordering code example:

R	I	L	-	O	8	W	-	R	H		
				08 DISPLAY INCREM. 1/8		W: WATER F: FOAM		R: LOW LEVEL WARNING	H: AUTOFILL HYST. xx/xx % R: ADD. OUTPUT	O: 1X 1.5A POSITIVE 1X 0.5A NEGATIVE	M: MUTE OUT1

***NOTE:** Selection of all three options R, H and L for the same indicator is standardly not possible. Options that are available are R, H, L and the combination RH

Master Indicator - Large

Ordering code example:

I	N	L	-	O	8	W	U	4	R	H		
				08 DISPLAY INCREM. 1/8		W: WATER F: FOAM	SENSOR INPUT / PROBE U4: 0.5-4.5V U1: 0-10 V I2: 4-20 MA RO: RESISTIVE IN		R: LOW LEVEL WARNING	H: AUTOFILL HYST. xx/xx % R: ADD. OUTPUT	O: 1X 1.5A POSITIVE 1X 0.5A NEGATIVE	M: MUTE OUT1

TANK LEVEL GAUGE

INS-20/RIS-20/TLGS-20



Features and Benefits

- 1 Super Bright 2 ½ -Digit LED Display
- 2 I/O Driver for Low-Water Warning, Autofill-Hysteresis, Mute input, Etc.
- 3 CAN Bus interface
- 4 Dimmable-Light Sensor
- 5 Multiple sensor input
- 6 Wide Viewing Angle
- 7 Low Installation Depth

INS-20 types of Tank Level Gauges are designed to display liquid's volume at an accuracy of 1/20 (5%) of the tank level, using ultra-bright 7-segment LED Displays. The transducer measures the column of the liquid in the tank above the sensor process input and provides a signal that is proportional to the tank height. The unit standardly uses pressure transducer with an output 0.5-4.5 V by which also broken sensor cable can be detected. The sensor input is widely configurable and can also be used for 0-10 V or 4-20 mA output signal.

Optionally, an I/O driver can be integrated for low level warning output, autofill-hysteresis output, mute input, etc.

The Tank Level Gauge can be used as a stand-alone system or as a part of MMX system connected via CAN bus to IO Controller. Several slave - remote indicators (RIS) can be connected to a master indicator INS to show the same value on different locations or in combination with a XL remote indicator (RIXL) for the vehicle sides.



SPECIFICATIONS

POWER	
Supply Voltage	8-32 V DC
Current	0.5 A maximum, no outputs active
Electrical Protection	overvoltage, transients, reverse polarity
INTERFACES	
CAN	1 x CAN
CAN termination	120 ohm, DIP switch
I/O	
Sensor input	0.5-4.5 V standardly, 0-5V, 0-10V, 4-20 mA, resistive
Digital Input	configurable active low/high levels 0..Ub with solder pad on PCB, protected
Digital Output	*Only version with integrated I/O driver positive switching (high-side), max. 2 A (Low water warning) positive switching (high-side), max. 2 A (Autofill-Hysteresis)
OUT1	
OUT2	
Loads	inductive, capacitive, resistive
Miscellaneous	Protection from short circuit and overload
ENVIRONMENT	
IP Class (IEC529)	IP67 front panel, IP20 from the back
EMC Conformity	EN61000-6-2 noise immunity EN61000-6-4 radiation of interference
Temperature Range	storage -40° to +85°C (-40° to 185°F) operating -40° to +85°C (-40° to 185°F)
ENCLOSURE	
Housing Material	aluminium
Mounting	in-dash, with 4 screws M3 or 3.5 mm (#8) tapping screws
Connector	Terminal block 8- or 10-way depending of options selected
MISCELLANEOUS	
Indicator increments	1/20 of tank height (5%)
Day/Night operation	automatic – integrated light sensor
Front panel	backlit, colour coded for water and foam
Detectable substances	water, fire-smothering foam, gasoline, etc
SIZE AND WEIGHT	
W x H x D	48 x 76 x 26 mm with connector
Weight	0.1 kg (0.22 lbs)



DIMENSIONS

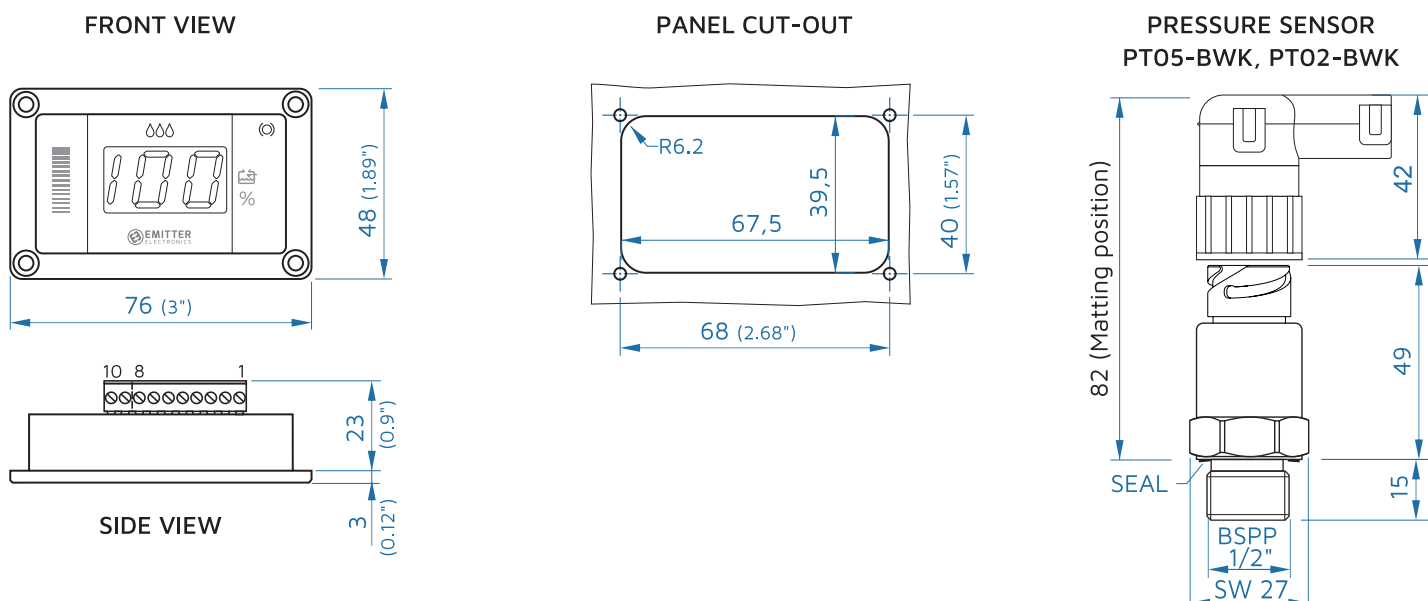

CONNECTIONS

TRANSDUCER OEM

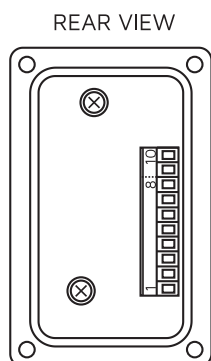

CONNECTION Terminal Block 8/10-way

PIN DESCRIPTION

1	BATTERY + (*15")
2	BATTERY - (GND)
3	CAN L
4	CAN H
5	SENSOR [V] OR [mA] VCC+
6	SENSOR [V] OR [mA] SIGNAL
7	SENSOR [V] GND
8	DIGITAL IN1 +/-
9	OUT1 HIGH SIDE 2 A (OPTIONAL)
10	OUT2 HIGH SIDE 2 A (OPTIONAL)

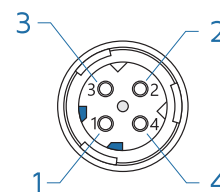

CONNECTION Twist Lock (ISO 15170)

PIN	VOLTAGE SENSOR	CURRENT SENSOR
1	BATTERY +	BATTERY +
2	GND	SIGNAL 4-20 MA
3	SIGNAL 0.5-4.5V	N/C
4	N/C	N/C

How to order (use characters in **bold** to create order code)

SET of indicator small INS-20, sensor PT05-U4 and mating connectors Ordering code example:

T	L	G	S	-	2	O	W	-	0	5	R	H
					20 DISPLAY INCREM. 1/20 (5%)	W : WATER F : FOAM	CABLE LENGTH, METERS (INCH) 05 : 5 M (20") 10 : 10 M (40") 15 : 15 M (60")			R : LOW LEVEL WARNING	H : AUTOFILL HYST. xx/xx % R : ADD. OUTPUT	

Indicator Small

Ordering code example:

I	N	S	-	2	O	W	U	4	R	H
					20 DISPLAY INCREM. 1/20 (5%)	W : WATER F : FOAM	SENSOR INPUT / PROBE U4 : 0.5-4.5V U1 : 0-10 V I2 : 4-20 MA RO : RESISTIVE IN		R : LOW LEVEL WARNING	H : AUTOFILL HYST. xx/xx % R : ADD. OUTPUT

REMOTE INDICATOR XL-NARROW

RIXLN



Features and Benefits

- 1 **Powerful Luminous Flux**
- 2 **Colour-Coded Led For Water And Foam Display**
- 3 **Five Different Level Patterns**
- 4 **Can Bus Or "T" Datalink**
- 5 **Low Installation Depth**
- 6 **Waterproof Aluminium Housing**

The XL Remote Tank Indicator RIXLN types are designed to display water or foam tank level, possible to be seen from a long distance. Blue, yellow and red LEDs are used for displaying water level and amber, yellow and red LEDs for foam. When the tank level is critical (liquid level less than 1/4) both indicators signalize the level with red colour LEDs, when the liquid level is less than 1/8 lights are running from top to bottom to signalize an empty tank.

The RIXLN needs to be connected either to a master indicator or to an IO node/controller when used in MMX configuration. Large tank indicator is a slave device. Several slave indicators can be connected over Can bus or "T"- one wire datalink to show the same value on different locations.

Housing is made of Aluminium, highly resistant to weather conditions (IP67) and can survive extreme environments, what makes it perfect for installation outside the vehicles. The level bars are large and well-spaced, allowing a reliable reading of level in bright viewing angle and direct sunlight.



SPECIFICATIONS

POWER

Supply Voltage 10-30 V DC

Current 1.5 A maximum

Power 16 W maximum

Electrical Protection overvoltage, transients, reverse polarity, load dump

INTERFACES

CAN 1 x CAN

T - one wire 1 x serial communication - optional

ENVIRONMENT

IP Class (IEC529) IP67, waterproof

EMC Conformity EN61000-6-2 noise immunity
EN61000-6-4 radiation of interference

Temperature Range storage -40° to +85°C (-40°F to 185°F)
operating -40° to +85°C (-40°F to 185°F)

ENCLOSURE

Housing Material Aluminium, glass

Mounting in-dash, with 4 screws M3 or 3.5 mm tapping screws

Connector Deutsch DT06-6S

MISCELLANEOUS

Indicator increments 0, 1/4, 1/2, 3/4, Full

LEDs colour water type 24 red, 24 yellow and 48 blue

LEDs colour foam type 24 red, 24 yellow and 48 amber

SIZE AND WEIGHT

W x H x D [mm] 66 x 373 x 15 without connector

Weight 0.6 kg

DIMENSIONS

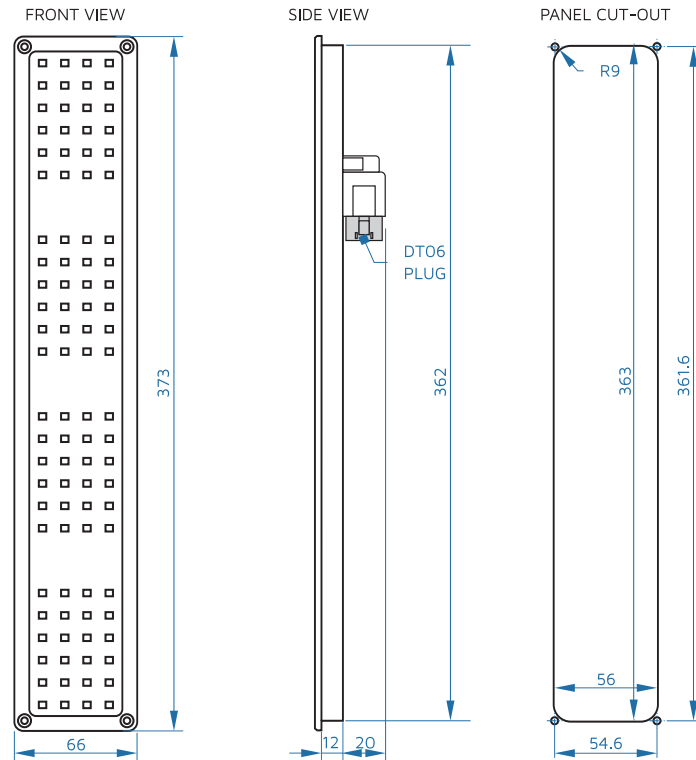

CONNECTIONS

TYPE WITH "T" one wire Connection Deutsch DT06-6S

PIN	DESCRIPTION
1	BATTERY + (*15")
2	T one wire datalink
3	T one wire datalink, int. shorted to PIN 2
4	N/A
5	N/A
6	BATTERY -

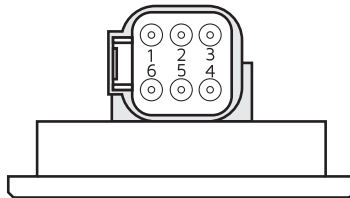

TYPE WITH Can BUS Connection Deutsch DT06-6S

PIN	DESCRIPTION
1	BATTERY + (*15")
2	CAN L
3	CAN L, int. shorted to PIN 2
4	CAN H
5	CAN H, int. shorted to PIN 4
6	BATTERY -

PRODUCT CODE

RIXLN-WRYBB-C	XL remote indicator narrow, for water, red, yellow, blue LEDs Can-bus datalink
RIXLN-FRYYY-C	XL remote indicator narrow, for foam, red, yellow LEDs, Can-bus datalink

For more options please contact the supplier.

REMOTE INDICATOR XL-WIDE

RIXLW

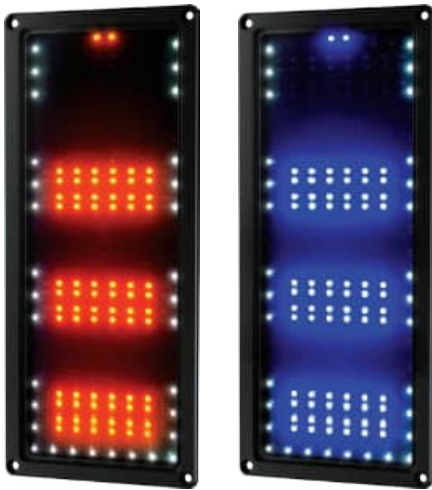

Features and Benefits

- 1 **Powerful Luminous Flux**
- 2 **Colour-Coded Led For Water And Foam Display**
- 3 **Six Different Level Patterns**
- 4 **Can Bus Or "T" Datalink**
- 5 **Low Installation Depth**
- 6 **Waterproof Aluminium Housing**

The XL Remote Tank Indicator RIXLW types are designed to display water or foam tank level, possible to be seen from a long distance. Blue LEDs are used for displaying water level and yellow LEDs for foam. When the tank level is critical (liquid level less than 1/4) both indicators signalize the level with red colour LEDs, when the liquid level is less than 1/8 lights are running from top to bottom to signalize an empty tank.

The RIXLW needs to be connected either to a master indicator or to an IO node/controller when used in MMX configuration. Large tank indicator is a slave device. Several slave indicators can be connected over Can bus or "T"- one wire datalink to show the same value on different locations.

Housing is made of Aluminium, highly resistant to weather conditions (IP67) and can survive extreme environments, what makes it perfect for installation outside the vehicles. The level bars are large and well-spaced, allowing a reliable reading of level in bright viewing angle and direct sunlight.



SPECIFICATIONS

POWER

Supply Voltage	10-30 V DC
Current	1.5 A maximum
Power	16 W maximum
Electrical Protection	overvoltage, transients, reverse polarity, load dump

INTERFACES

CAN	1 x CAN
T - one wire	1 x serial communication - optional

ENVIRONMENT

IP Class (IEC529)	IP67, waterproof
EMC Conformity	EN61000-6-2 noise immunity EN61000-6-4 radiation of interference
Temperature Range	storage -40° to +85°C (-40°F to 185°F) operating -40° to +85°C (-40°F to 185°F)

ENCLOSURE

Housing Material	Aluminium, glass
Mounting	in-dash, with 4 screws M5 or 4.8 mm tapping screws
Connector	Deutsch DT06-6S

MISCELLANEOUS

Indicator increments	0, 1/8, 1/4, 1/2, 3/4, Full
LEDs colour water type	96 blue, 24 red and 32 white for surround
LEDs colour foam type	96 yellow, 24 red and 32 white for surround

SIZE AND WEIGHT

W x H x D [mm]	146 x 321 x 15 without connector
Weight	1 kg

DIMENSIONS

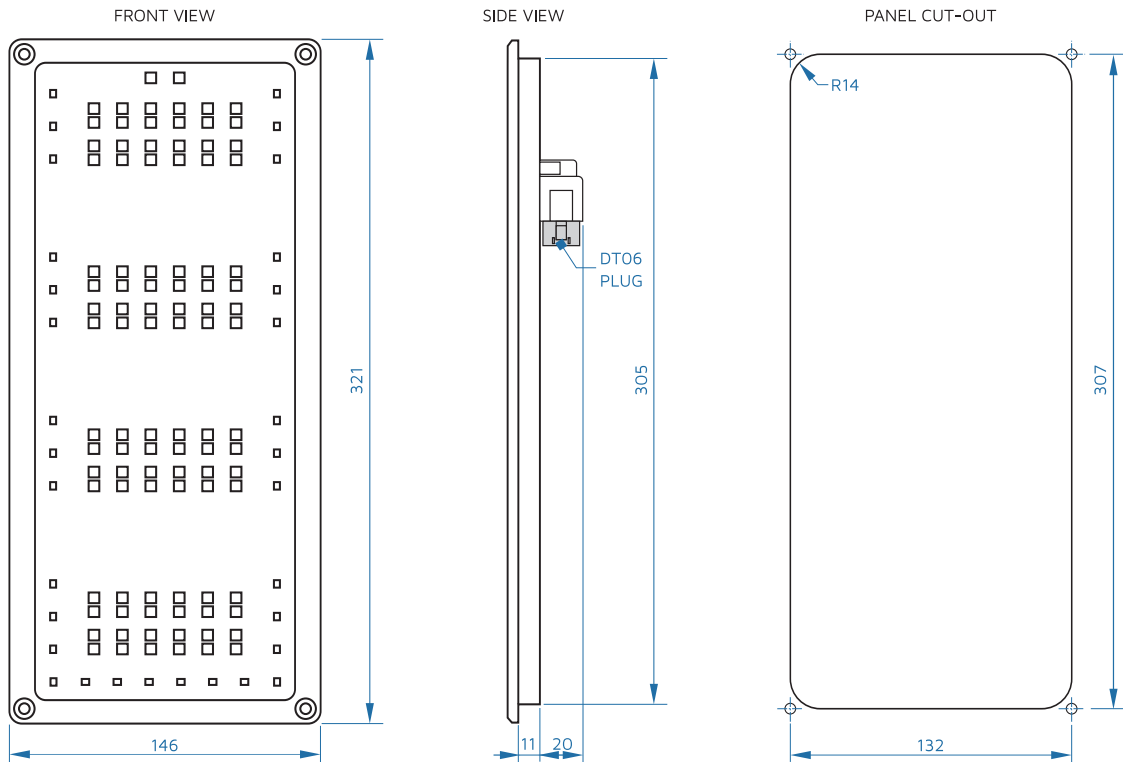

CONNECTIONS

TYPE WITH "T" one wire Connection Deutsch DT06-6S

PIN	DESCRIPTION
1	BATTERY + (*15")
2	T one wire datalink
3	T one wire datalink, int. shorted to PIN 2
4	N/A
5	N/A
6	BATTERY -

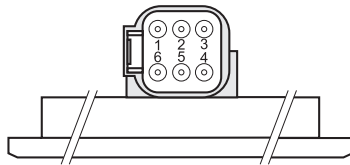

TYPE WITH Can BUS Connection Deutsch DT06-6S

PIN	DESCRIPTION
1	BATTERY + (*15")
2	CAN L
3	CAN L, int. shorted to PIN 2
4	CAN H
5	CAN H, int. shorted to PIN 4
6	BATTERY -

PRODUCT CODE

RIXLW-WBR-C	XL remote indicator wide, for water, blue/red LEDs, Can-bus datalink
RIXLW-FYR-C	XL remote indicator wide, for foam, yellow/red LEDs, Can-bus datalink

For more options please contact the supplier.

DIGITAL PRESSURE INDICATOR - 3 DIGIT

DPI-XXXX / RPI / DPG-XXXX



Features and Benefits

- 1 Vacuum, Low and High Pressure Indication options
- 2 3-Digit Super Bright LED Display
- 3 Dimmable – Light Sensor
- 4 I/O Driver integrated for Alarms, Regulation, Etc. – Optional
- 5 CAN Bus Interface
- 6 Wide Viewing Angle
- 7 Multiple Sensor input

DPI types of Digital Pressure Indicators are designed to display system pressure using a 3 - digit ultra-bright LED display where multiple pressure sensors can be connected.

The unit standardly uses -1..24 bar, 0..25 bar or 0..60 bar pressure sensors. The sensor input is widely configurable and can be used for 0.5-4.5 V and 0-10 V transducers or 4-20 mA transmitters.

Optionally, an I/O driver can be integrated for activating warning output, regulating the system pressure, etc.

The Digital Pressure Indicator can be used as a stand-alone system or as a part of MMX system connected via CAN bus to IO Controller. Several slave-remote pressure indicators (RPI) can be connected to a master indicator (DPI) to show the same value on different locations.

SPECIFICATIONS

POWER

Supply Voltage	8-32 V DC
Current	0.5 A maximum, no outputs active
Electrical Protection	overvoltage, transients, reverse polarity

INTERFACES

CAN	1 x CAN
CAN termination	120 ohm, DIP switch

I/O

Sensor input	0.5-4.5 V standardly, 0-5V, 0-10V, 4-20 mA
Digital Input	configurable active low/high levels 0..Ub with solder pad on PCB, protected
Digital Output OUT1	<i>*Only version with integrated I/O driver</i> positive switching (high-side), max. 2 A (Low water warning)
OUT2	positive switching (high-side), max. 2 A (Autofill-Hysteresis)
Loads	inductive, capacitive, resistive
Miscellaneous	Protection from short circuit and overload

ENVIRONMENT

IP Class (IEC529)	IP67 front panel, IP20 from the back
EMC Conformity	EN61000-6-2 noise immunity EN61000-6-4 radiation of interference
Temperature Range	storage -40° to +85°C (-40° to 185°F) operating -40° to +85°C (-40° to 185°F)

ENCLOSURE

Housing Material	aluminium
Mounting	in-dash, with 4 screws M3 or 3.5 mm (#8) tapping screws
Connector	Terminal block 8 or 10-way depending of options selected

MISCELLANEOUS

LED display	3 - digit
Reading resolution	@P<30 bar: 0.1 bar, @P>30 bar: 1 bar
Day/Night operation	automatic – integrated light sensor

SIZE AND WEIGHT

W x H x D	48 x 76 x 26 mm with connector
Weight	0.1 kg (0.22 lbs)



DIMENSIONS

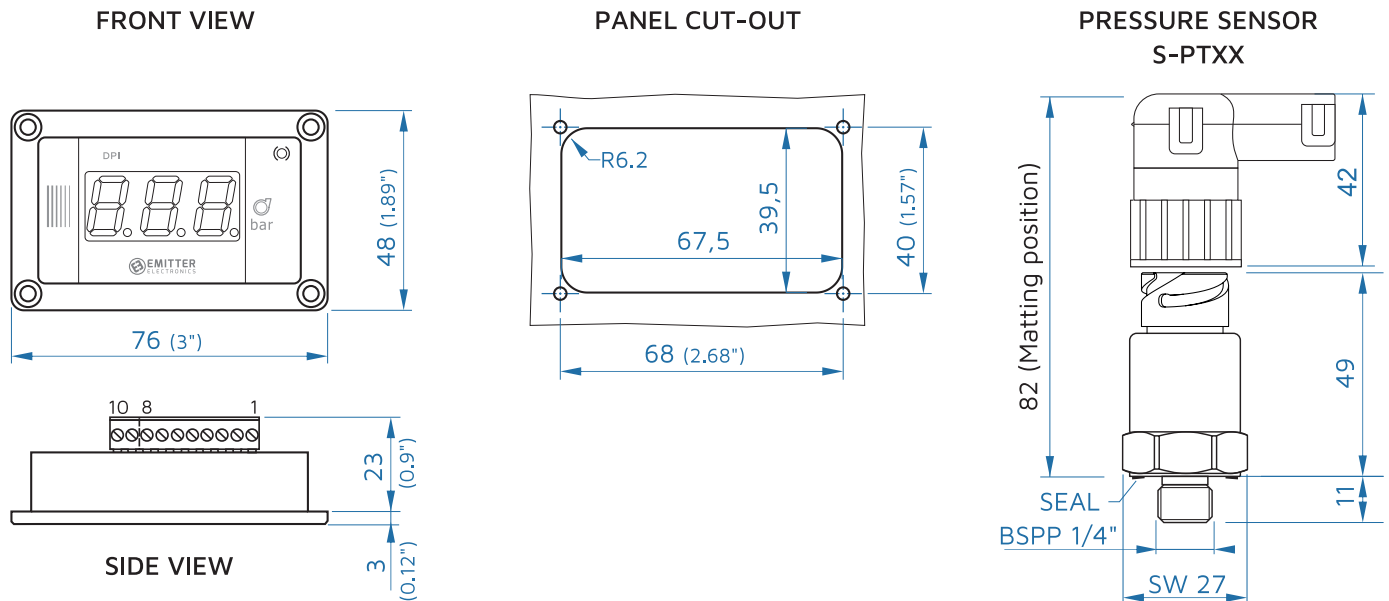

CONNECTIONS

TRANSDUCER OEM

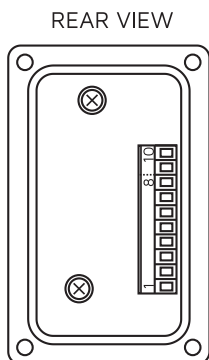

CONNECTION Terminal Block 8/10-way

PIN DESCRIPTION

1	BATTERY + (*15")
2	BATTERY - (GND)
3	CAN L
4	CAN H
5	SENSOR [V] OR [mA] VCC+
6	SENSOR [V] OR [mA] SIGNAL
7	SENSOR [V] GND
8	DIGITAL IN1 +/-
9	OUT1 HIGH SIDE 2 A (OPTIONAL)
10	OUT2 HIGH SIDE 2 A (OPTIONAL)

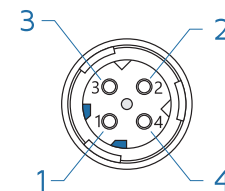

CONNECTION Twist Lock (ISO 15170)

PIN	VOLTAGE SENSOR	CURRENT SENSOR
1	BATTERY +	BATTERY +
2	GND	SIGNAL 4-20 MA
3	SIGNAL 0.5-4.5V	N/C
4	N/C	N/C

How to order (use characters in **bold** to create order code)

SET of DPI-master indicator, pressure sensor, sensor cable Ordering code example:

D	P	G	-	0	0	2	5	-	R	H	
MEASURING RANGE				OUT1				OUT2		SPECIAL	
0024: -1 ... 24 BAR				R: OUTPUT 1				H: HYST. xx/xx %		MODIFICATION	
0025: 0 ... 25 BAR								R: ADD. OUTPUT			
0060: 0 ... 60 BAR											

Master Indicator

D	P	I	-	0	0	2	5	U	4	R	H
MEASURING RANGE				SENSOR INPUT /				OUT1		OUT2	
0024: -1 ... 24 BAR				PROBE				R: OUTPUT 1		H: HYST. xx/xx %	
0025: 0 ... 25 BAR				U4: 0.5-4,5V						R: ADD. OUTPUT	
0060: 0 ... 60 BAR				U1: 0-10 V							
				I2: 4-20 MA							

Remote Indicator

R	P	I	-	0	0	2	5	-	R	H	
MEASURING RANGE				OUT1				OUT2		SPECIAL	
0024: -1 ... 24 BAR				R: OUTPUT 1				H: HYST. xx/xx %		MODIFICATION	
0025: 0 ... 25 BAR								R: ADD. OUTPUT			
0060: 0 ... 60 BAR											

DIGITAL PRESSURE INDICATOR - 4 DIGIT

DPI-XXXX / RPI / DPG-XXXX



Features and Benefits

- 1 Vacuum, Low and High Pressure Indication
- 2 4-Digit [kPa] Display Version
- 3 I/O Driver integrated for Alarms, Regulation, Etc. - Optional
- 4 CAN Bus Or One Wire Datalink
- 5 Super Bright LED Display
- 6 Multiple Sensor input

DPI types of Digital Pressure Indicators are designed to display system pressure using 3 or 4-digit ultra-bright LED display where multiple pressure sensors can be connected. The unit standardly uses a -1..24 bar, 0..25 bar and 0..60 bar pressure sensors. The sensor input is widely configurable and it can be used for 0.5-4.5 V and 0-10 V transducers or 4-20 mA transmitters.

Optional I/O driver can be integrated for activating warning output, regulating the system pressure, etc.

The Digital Pressure Indicator can be used as a stand-alone system or as a part of MMX system connected via CAN bus to IO Controller. Several slave-remote pressure indicators (RPI) can be connected to a master indicator DPI to show the same value on different locations.



SPECIFICATIONS

POWER

Supply Voltage	9-30 V DC
Current	0.5 A maximum, no outputs active
Electrical Protection	overvoltage, transients, reverse polarity

INTERFACES

CAN	1 x CAN, optional
CAN termination	120 ohm, solder pad on PCB
Serial communication	1 x T (1 Wire), optional

I/O

Sensor input	0.5-4.5 V Standardly, 0-5V, 0-10V, 4-20 mA
Digital Input	GND, only with CAN bus device
Digital Output	<i>*Only version with integrated I/O driver</i>
OUT1	positive switching (relay), max. 6 A (Low water warning)
OUT2	positive switching (relay), max. 1.5 A (Autofill-Hysteresis)
OUT3-OUT7	negative switching (low-side), max. 1.8 A (large light driver)

Loads	inductive, resistive
--------------	----------------------

ENVIRONMENT

IP Class (IEC529)	front panel IP67, back IP20
EMC Conformity	EN61000-6-2 noise immunity EN61000-6-4 radiation of interference
Temperature Range	storage -40° to +85°C (-40° to 185°F) operating -40° to +85°C (-40° to 185°F)

ENCLOSURE

Housing Material	NORYL with glass-fibre reinforcement
Mounting	in-dash, with clips or springs
Connector	Terminal block 4, 8 or 13 way depending on selected options

MISCELLANEOUS

LED display	4 digit (kPa)
Reading resolution	@P<30 bar: 0.1 bar (10 kPa), @P>30 bar: 1 bar

SIZE AND WEIGHT

W x H x D	36 x 72 x 68 mm with connector
Weight	0.1 kg



DIMENSIONS

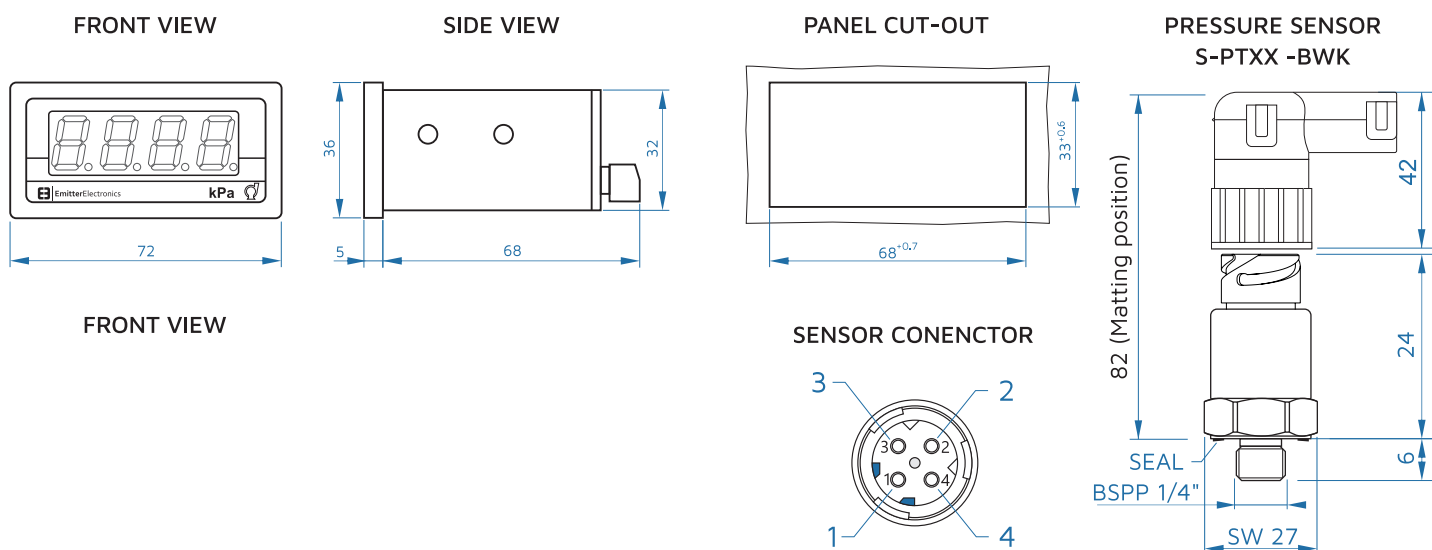

CONNECTIONS

CONNECTION standard device

PIN	DESCRIPTION
1	BATTERY + (*15")
2	BATTERY -
3	OUT1 (OPTIONAL)
4	T-COMMUNICATION
5	SENSOR [V] GND
6	SENSOR [V]/[mA] SIGNAL
7	SENSOR [V]/[mA] VCC+
8	OUT2 (OPTIONAL)
9	OUT3 (OPTIONAL)
10	OUT4 (OPTIONAL)
11	OUT5 (OPTIONAL)
12	OUT6 (OPTIONAL)
13	OUT7 (OPTIONAL)

CONNECTION CAN bus device

PIN	DESCRIPTION
1	BATTERY + (*15") / SENSOR SUPPLY (OPTIONAL)
2	BATTERY - / SENSOR GND (OPTIONAL)
3	OUT1 (OPTIONAL)
4	T-COMMUNICATION / OUT3 (OPTIONAL)
5	IN1
6	SENSOR [V]/[mA] SIGNAL
7	OUT2 (OPTIONAL)
8	SENSOR [V]/[mA] VCC+ / OUT4 (OPTIONAL)
9	OUT5 (OPTIONAL)
10	SENSOR [V] GND / OUT6 (OPTIONAL)
11	OUT7 (OPTIONAL)
12	CAN L
13	CAN H

TRANSDUCER OEM

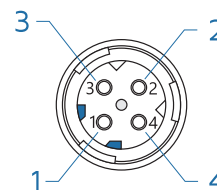

CONNECTION Twist Lock (ISO 15170)

PIN	VOLTAGE SENSOR	CURRENT SENSOR
1	BATTERY +	BATTERY +
2	GND	SIGNAL 4-20 MA
3	SIGNAL 0.5-4.5V	N/C
4	N/C	N/C

How to order (use characters in **bold** to create order code)

SET of DPI - master Indicator, pressure sensor, sensor cable

Ordering code example:

D	P	G	-	O	O	2	5	T	-	O	5	R	R	
MEASURING RANGE				T: 1 WIRE		CABLE LENGTH, METERS (INCH)		OUT1		OUT2		SPECIAL		
0024: -1 .. 24 BARS				C: CAN BUS		05: 5 M (20")		R: OUTPUT 1		H: HYSTERESIS		MODIFICATION		
0025: 0 .. 25 BARS						10: 10 M (40")				R: ADD. OUTPUT				
0060: 0 .. 60 BARS						15: 15 M (60")								
2200: 0 .. 2200 KPA														

Remote Indicator

Ordering code example:

R	P	I	-	B	T	I	R	R	
UNITS:		T: 1 WIRE		LED BRIGHTNESS		OUT1		OUT2	
B: BAR		C: CAN BUS		I: INSIDE		R: OUTPUT 1		H: HYSTERESIS	
P: KPA				O: OUTSIDE				R: ADD. OUTPUT	

Master Indicator

Ordering code example:

D	P	I	-	O	O	2	5	I	2	T	R	R		
MEASURING RANGE				SENSOR INPUT / PROBE				T: 1 WIRE		OUT1		OUT2		SPECIAL
0024: -1 .. 24 BARS				U4: 0,5-4,5V				C: CAN BUS		R: OUTPUT 1		H: HYSTERESIS		MODIFICATION
0025: 0 .. 25 BARS				U1: 0-10 V								R: ADD. OUTPUT		
0060: 0 .. 60 BARS				I2: 4-20 MA										
2200: 0 .. 2200 KPA														

PRESSURE TRANSMITTERS/ TRANSDUCERS



Features and Benefits

- 1 **Standard output signal 0.5 ... 4.5 V, 4-20mA or 0-10V**
- 2 **Silicon based diaphragms – high sensitivity**
- 3 **Automotive Heavy-duty ISO15170 sealed circular connector, twist lock**
- 4 **Robust and compact design**
- 5 **Non-linearity: < 1 % FS**
- 6 **Over-pressure safety: x 5**
- 7 **Material: 316L**
- 8 **Vacuum resistant**
- 9 **Universal Supply Voltage: 8 .. 30 VDC**

The PTxx series pressure transmitters have been designed for a wide range of industrial applications. They are capable of measuring pressure in water, gases, or vapors in systems such as liquid level monitoring, pump control, and machine building.

The gauge sensors use silicon-based sensing diaphragms with high elasticity, combined with semiconductor strain gauges implanted into the silicon substrate. This configuration provides excellent sensitivity, high overpressure resistance, and precise measurement characteristics with low non-linearity, minimal hysteresis, and high repeatability.

The relative pressure models rated for 25 bar and 60 bar employ ceramic capacitive measuring cells, ensuring robust performance in demanding environments.

Thanks to their technical specifications, reliability, and cost-effectiveness, these pressure transmitters are especially well suited for OEM applications.



SPECIFICATIONS

POWER SUPPLY AND OUTPUT SIGNAL

Supply Voltage	9-30 V DC
Voltage output Signal	0.5-4.5 V standard 0-10 V optionally
Current output Signal	4 .. 20 mA optionally
Load in ohm	<(U _{batt} -9V)/0.02A

ELECTRICAL CONNECTION

Connector type	ISO15170 2.5mm system, Key1, Twist Lock (Bayonet)
-----------------------	---

Pin assignment 0.5 .. 4.5 V signal, type PTxx-U4-BWK	1: U batt + 2: GND 3: Signal out 0.5 .. 4.5V 4: N/C
--	--

Pin assignment 4..20 mA signal type, PTxx-I2-BWK	1: U batt + 2: Signal out 4..20mA 3: N/C, 4: N/C
--	--

ENVIRONMENT

Temperature range	operating from -20°C to +70°C (temp. compensation range) storage from -45°C to +85°C
--------------------------	---

Ingress protection (IEC60529)	IP67 (mated position)
--------------------------------------	-----------------------

Mating connector	ISO15170 2.5mm system, Key1, Twist Lock, angled, for corrugated tube NW 8.5 with 2 or 3 conatcts and one or two seal plug
Current sensors P/N	CKIT ISO2-9NW8.5
Voltage sensors P/N	CKIT ISO3-9NW8.5

Wire cross-section	0.5 .. 1 mm ²
Wire insulation diameter	1.2 mm .. 2.1 mm



SPECIFICATIONS

PRESSURE SENSOR PT05-BWK, PT02-BWK

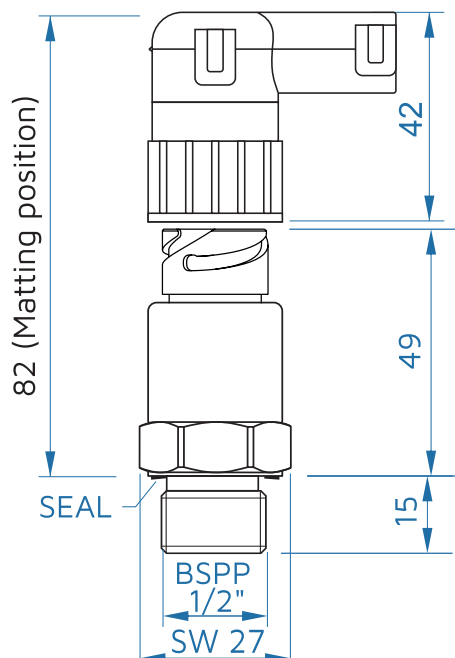

SENSOR CONECTOR

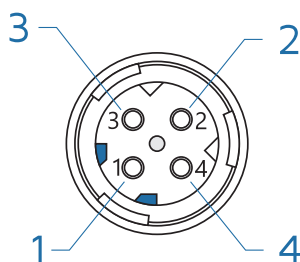

PRESSURE SENSOR S-PTXX -BWK

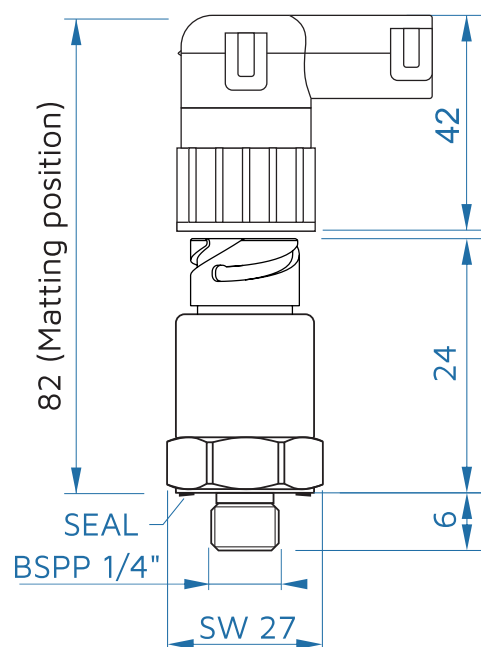

GAUGE SENSOR PRESSURE RANGE

Measuring range

- PT02-xx-BWK 0 .. 200 mBar
- PT05-xx-BWK 0 .. 500 mBar

Overpressure and burst limit

- 200 mbar transducers 1000 mBar
- 500 mbar transducers 2500 mBar

Vacuum tightness

Yes

ACCURACY

Accuracy

< 0.5 % FS

CONNECTION

Process connection

G 1/2", BSPP

RELATIVE SENSOR PRESSURE RANGE

Measuring range

- PT24-xx-BWK -1 .. 24 bar
- PT25-xx-BWK 0 .. 25 bar
- PT60-xx-BWK 0 .. 60 bar

Overpressure and burst limit

4 bar, 25 bar and 60 bar sensors 100 bar

Vacuum tightness

Yes

ACCURACY

Accuracy

< 1 % FS

CONNECTION

Process connection

G 1/4", BSPP

How to order (use characters in **bold** to create order code)

SET of DPI - master Indicator, pressure sensor, sensor cable

Ordering code example:

S	-	P	T	0	5	-	U	4	-	B	W	K
SET S : SET WITH MATING CONNECTOR		SENSOR TYPE		PRESSURE RANGE: 02 : 0-200 mBAR 05 : 0-500 mBAR 24 : -1-24 BAR 25 : 0-25 BAR 60 : 0-60 BAR, ETC			OUTPUT SIGNAL U4: 0.5-4.5V U1: 0-10V I2: 4-20MA			CONNECTOR AND IDENTIFIER BWK : BAYONET-TWIST LOCK		

FLASHER



Features and Benefits

- 1 **2 Channels**
- 2 **High Current Low Side Mosfet Outputs**
- 3 **Powered by either 12 or 24V**
- 4 **Factory Programmable**
- 5 **Ready for Immediate Operation**

Flasher is an electronic device with two independent low side output signals which can control for e.g flash lamps mounted on the front, rear or on the vehicle sides, warning for open steps etc.

The flasher can be programmed to different flashing user patterns.

DIMENSIONS

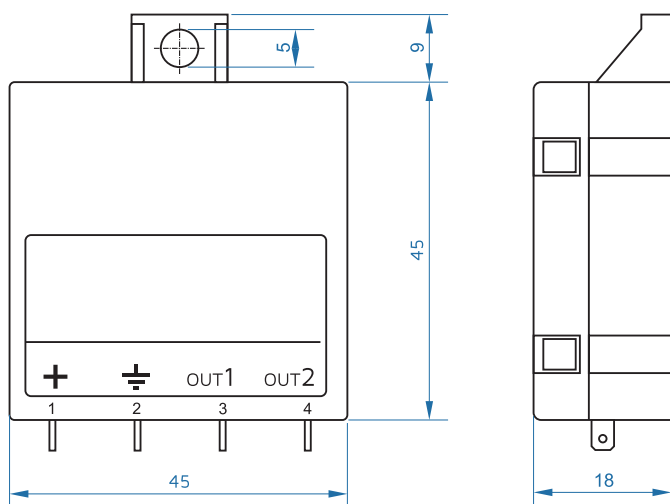

SPECIFICATIONS

POWER

Supply Voltage	8-30 V DC
Current	0.1 A maximum, no outputs active
Electrical Protection	reverse polarity

I/O AND INTERFACES

Digital Output

OUT1	negative switching (low-side), max. 2 A
OUT2	negative switching (low-side), max. 2 A

Loads	inductive, resistive
--------------	----------------------

ENVIRONMENT

IP Class (IEC259)	IP20
Temperature Range	storage from -40° to +85°C operating from -40° to +85°C

ENCLOSURE

Housing Material	ABS
Mounting	with 1 screw
Connector	faston 2.8 x 0.8

SIZE AND WEIGHT

W x H x D	45 x 45 x 18 mm without connector
Weight	0.1 kg

PRODUCT CODE

FLASHER 2N	Flasher 2x Output GND, 1A, 10-30V DC, fact. programmable
-------------------	--

PTO TIMER



Features and Benefits

- 1 **2 Channels- Clutch and PTO control**
- 2 **Positive or Negative Relay Outputs**
- 3 **Pulse or Permanent PTO engagement procedure**
- 4 **Powered by either 12 or 24V**
- 5 **Factory Programmable**
- 6 **Ready for Immediate Operation**

The vehicle PTO engagement and disengagement action uses the main transmission clutch and a control mechanism which physically engage the PTO itself. Typically, an air valve is used to engage the PTO. There are a number of different types of PTO and different engagement procedures.

The PTO TIMER is designed to manage the proper engagement of PTO with two control signals, one for clutch and another for PTO valve. It is factory programmed to specific chassis brands and types. The control and activation signal can be permanent or pulse and positive or negative.

DIMENSIONS

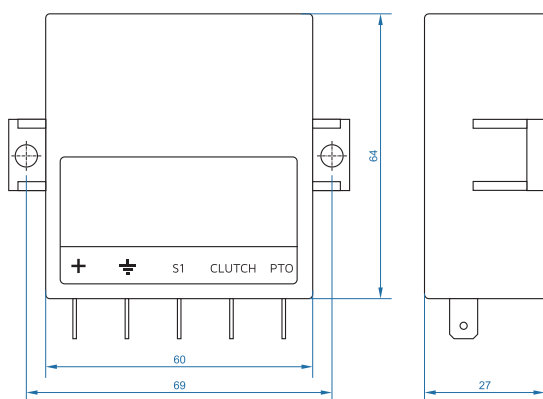

SPECIFICATIONS

POWER	
Supply Voltage	8-30 V DC
Current	0.2 A maximum, no outputs active
Electrical Protection	reverse polarity, overvoltage
I/O AND INTERFACES	
Relay Output	
OUT1	negative or positive switching, max. 1 A
OUT1	negative or positive switching, max. 1 A
Loads	inductive, resistive
ENVIRONMENT	
IP Class (IEC259)	IP20
Temperature Range	storage from -40° to +85°C operating from -40° to +85°C
ENCLOSURE	
Housing Material	ABS
Mounting	with 2 screw
Connector	faston 6.3 x 0.8
SIZE AND WEIGHT	
W x H x D	60 x 60 x 27 mm without connector
Weight	0.1 kg

PRODUCT CODE

PTO24VI+-I	PTO-TIMER-24-I-8+/3/4-, clutch +, pto -(pulse), switch input-permanent, Renault
PTO24VP+-	PTO-TIMER-24-P-5+/3, clutch +, pto -, Scania/Iveco
PTO24VP++	PTO-TIMER-24-P-5+/3, clutch +, pto +, MAN/Mercedes

CONNECTIONS

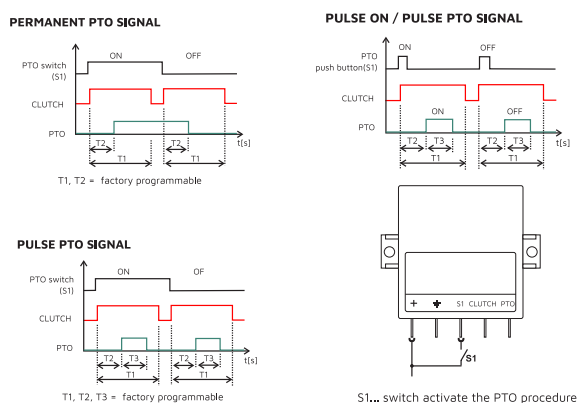



DEVELOPMENT ON DEMAND

We can make products tailored
to your needs and requirements!
Contact us for your
future application.



EMITTER ELECTRONICS

Innovative, reliable, flexible

COMPANY



EMITTER ELECTRONICS

Tržaška cesta 65
SI-2000 Maribor
Slovenia, Europe

phone +386 5 995 1 973

info1@emitter.org
www.emitter.org

DISTRIBUTOR FOR AUSTRALIA



BELL ENVIRONMENTAL (Melbourne)

68 Berkshire Road
Sunshine, Victoria, 3020
Australia

phone (03) 8582 1861

info@bellenvironmental.com.au
<http://bellenvironmental.com.au>

DISTRIBUTOR FOR SOUTH KOREA



HYDROFAST CO, LTD

C-610, Woolim Lion's Valley
283 Bupyeong-Daero
INCHEON 21315
SOUTH KOREA

phone + 82 32 623 5015

www.hydrofast.co.kr